

## Surgical Technique



Acumed® is a global leader of innovative orthopaedic and medical solutions.



We are dedicated to developing products, service methods, and approaches that improve patient care.

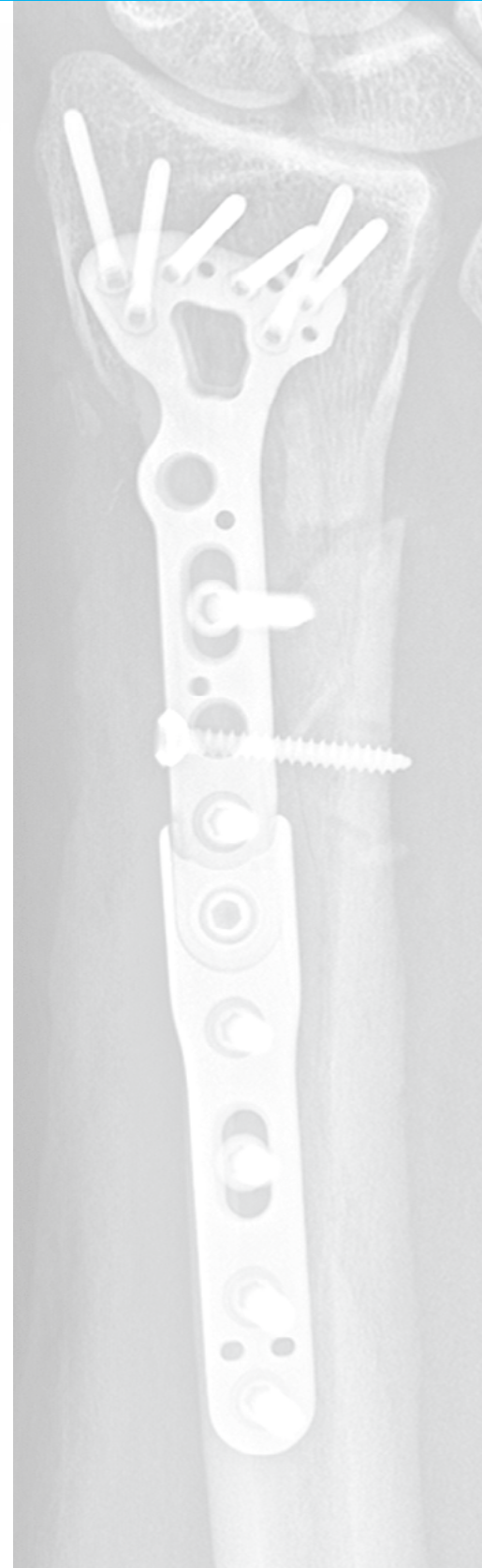

## Acumed® Acu-Loc® 2 Wrist Plating System

The Acu-Loc 2 Wrist Plating System offers various plate families and screw technologies to treat multiple fracture patterns of the distal radius and distal ulna regions. Included are the Volar Distal Ulna Plates and the Volar, Dorsal, and Fragment Specific Distal Radius Plates.

Acumed has introduced the Acu-Loc 2 Volar Distal Radius (VDR) Plating System as the next generation in plating fixation. The system presents several new plate options, a unique two-piece locking compression screw, innovative instrumentation for fracture management, and new plate placement tools.

Some products shown and/or described may not be available in your distribution area. Please contact your local authorized Acumed distributor for any further information.

	Definition
<b>Warning</b>	Indicates critical information about a potential serious outcome to the patient or the user.
<b>Caution</b>	Indicates instructions that must be followed in order to ensure the proper use of the device.
<b>Note</b>	Indicates information requiring special attention.

# Table of Contents

Acu-Loc 2 System Features .....	<b>2</b>
Plate Placement Instrumentation .....	<b>12</b>
Instrument Overview .....	<b>13</b>
Surgical Technique Overview.....	<b>16</b>
Surgical Techniques .....	<b>20</b>
Acu-Loc 2 Volar Distal Radius (VDR) Surgical Technique.....	<b>20</b>
Distal Radius Fragment Specific (DRFS) Surgical Technique.....	<b>26</b>
Radial Styloid Plate Surgical Technique .....	<b>28</b>
Volar Lunate Suture Plate Surgical Technique.....	<b>29</b>
Dorsal Lunate Plate and Dorsal Rim Buttress Plate Surgical Technique .....	<b>30</b>
Acu-Loc Volar Distal Ulna (VDU) Plate Surgical Technique .....	<b>32</b>
Acu-Loc Dorsal Plate Surgical Technique .....	<b>36</b>
Acu-Loc Extra-Articular (EX) Plate Surgical Technique.....	<b>41</b>
Frag-Loc Compression Screw Surgical Technique .....	<b>46</b>
2.3 mm Locking Variable Angle Screw Surgical Technique.....	<b>49</b>
Volar Ulnar Corner Fixation.....	<b>52</b>
Ordering Information .....	<b>54</b>
References .....	<b>73</b>

# System Features

## Acu-Loc 2 Volar Distal Radius (VDR) Plates

The standard Acu-Loc 2 Plate is designed to closely replicate the anatomical contours of the distal radius and may assist in restoring the original geometry. The 2.3 mm Locking Variable Angle Screws can be used in the distal styloid hole only for all silver-colored Acu-Loc 2 VDR Plates. Please see the 2.3 mm Locking Variable Angle Screw section for additional information.

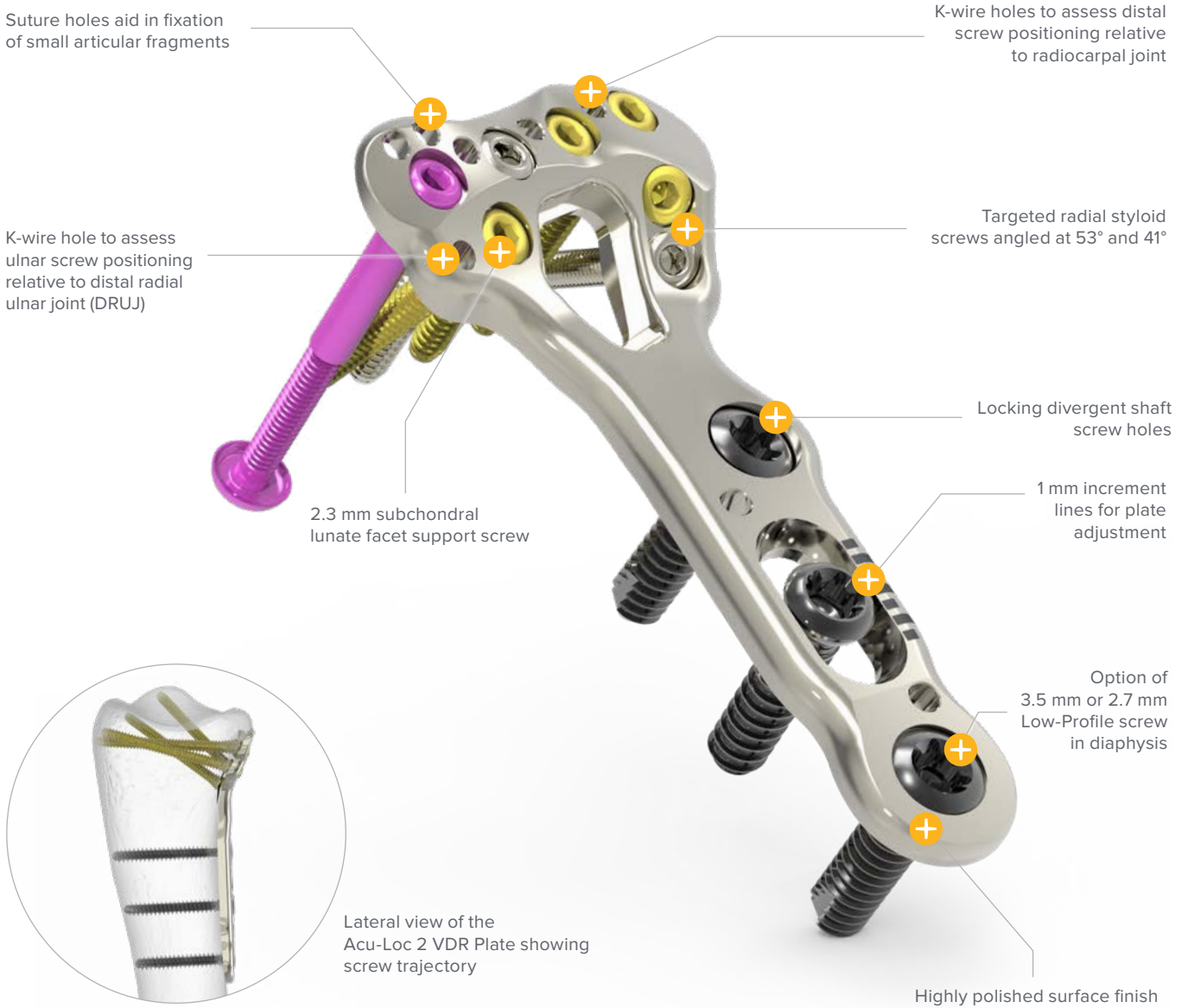

### Acu-Loc 2 VDR Plate Options

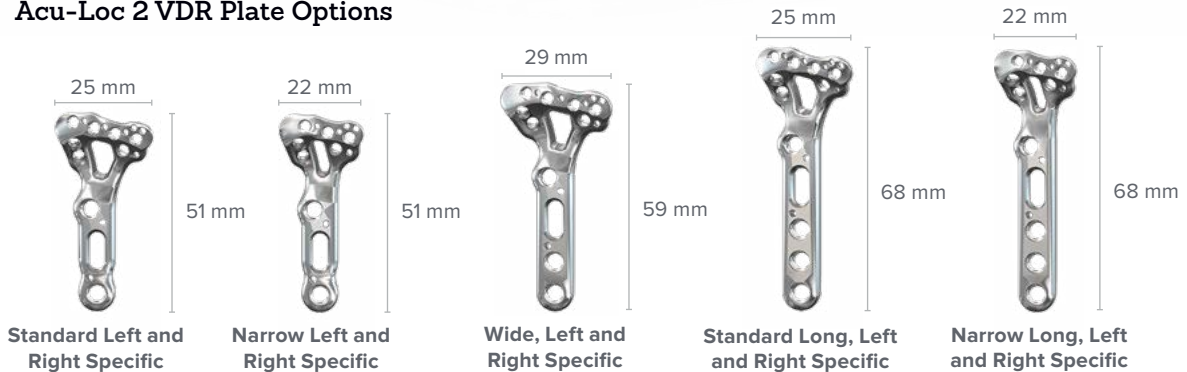



# System Features [continued]

## Acu-Loc 2 Volar Distal Radius (VDR) Proximal Plates

VDR Proximal Plates are designed to sit approximately 2 mm more proximal than the VDR Standard Plates. All 2.3 mm screws in the system, including the locking variable angle screws, may be used in any 2.3 mm screw hole of the Acu-Loc 2 VDR Proximal Plates. Please see the 2.3 mm Locking Variable Angle Screw section for additional information.

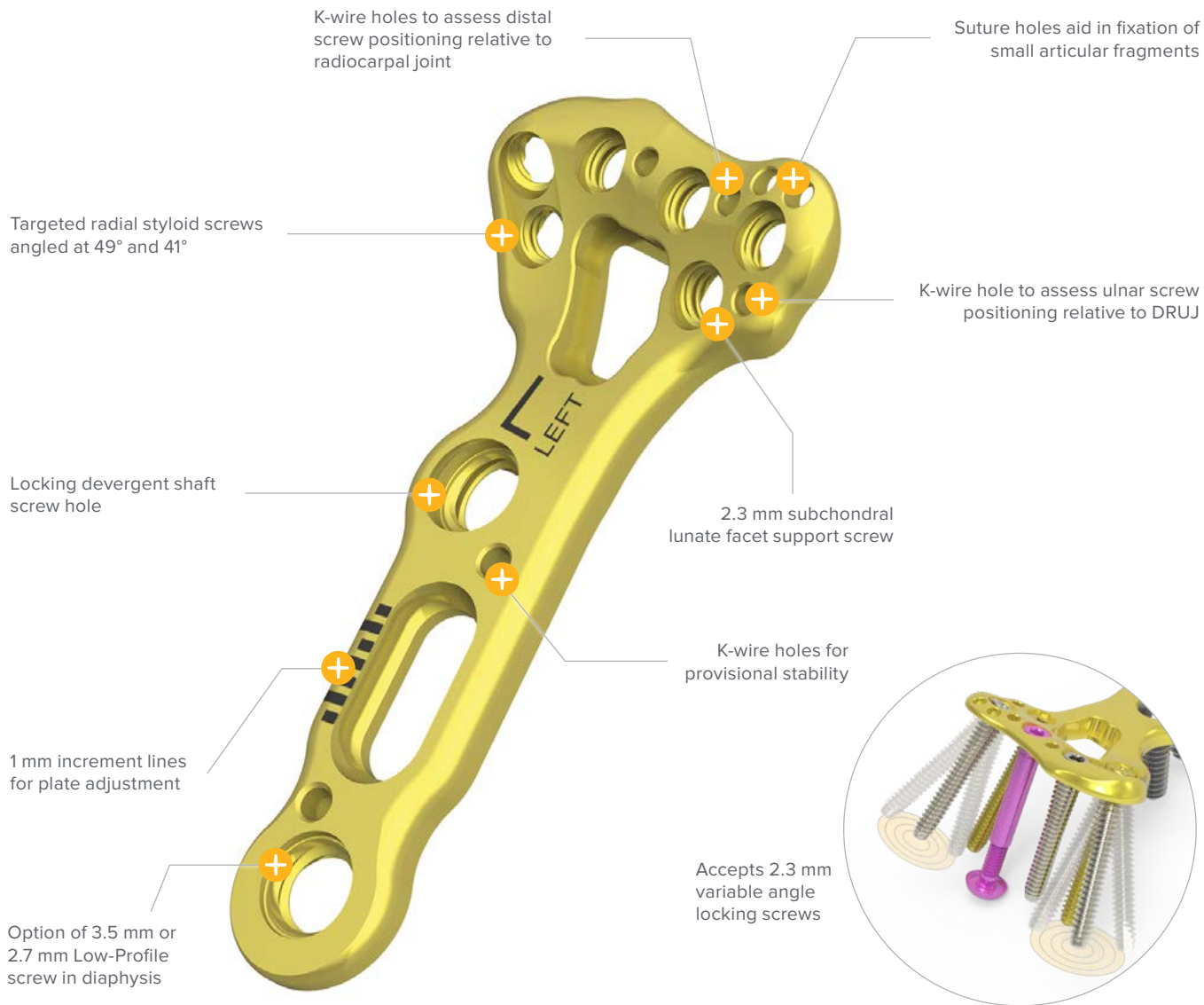

### Acu-Loc 2 VDR Proximal Plate Options

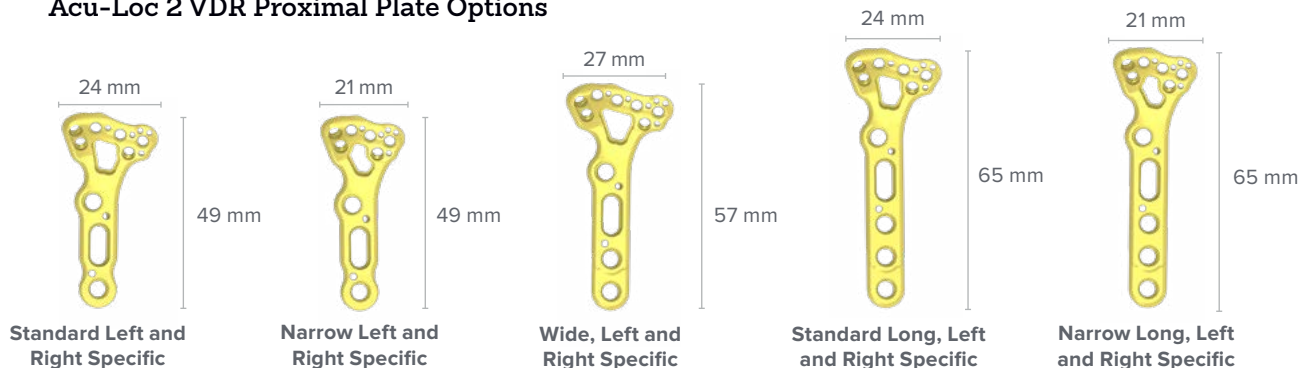

# System Features [continued]

## Acu-Loc 2 VDR Extension Plates

The Acu-Loc 2 VDR Plating System includes the ability to extend the Acu-Loc 2 VDR Proximal Plates. The Acu-Loc 2 VDR Extension Plates are rigidly locked with a Acu-Loc 2 VDR Plate (hex) Extension Link Screw (30-0093) or Acu-Loc 2 VDR Hexalobe Extension Link Screw (30-0100) to the following Acu-Loc 2 VDR Proximal Plates:

- ▶ Acu-Loc 2 VDR Proximal Standard Long Plates
- ▶ Acu-Loc 2 VDR Proximal Narrow Long Plates
- ▶ Acu-Loc 2 VDR Proximal Wide Plates

### Long Extension Plates

Modular plate attachments allow surgeons to extend any of the long and wide proximal plates by an additional 110 mm. This option has both left and right plates to accommodate the radial bow. Plates are connected by a hex or hexalobe link screw.

**Warning:** The 2.7 mm Low-Profile Hexalobe Screw is not designed to be used with the Acu-Loc 2 Extension Plate (70-0364, 70-0365, 70-0366).

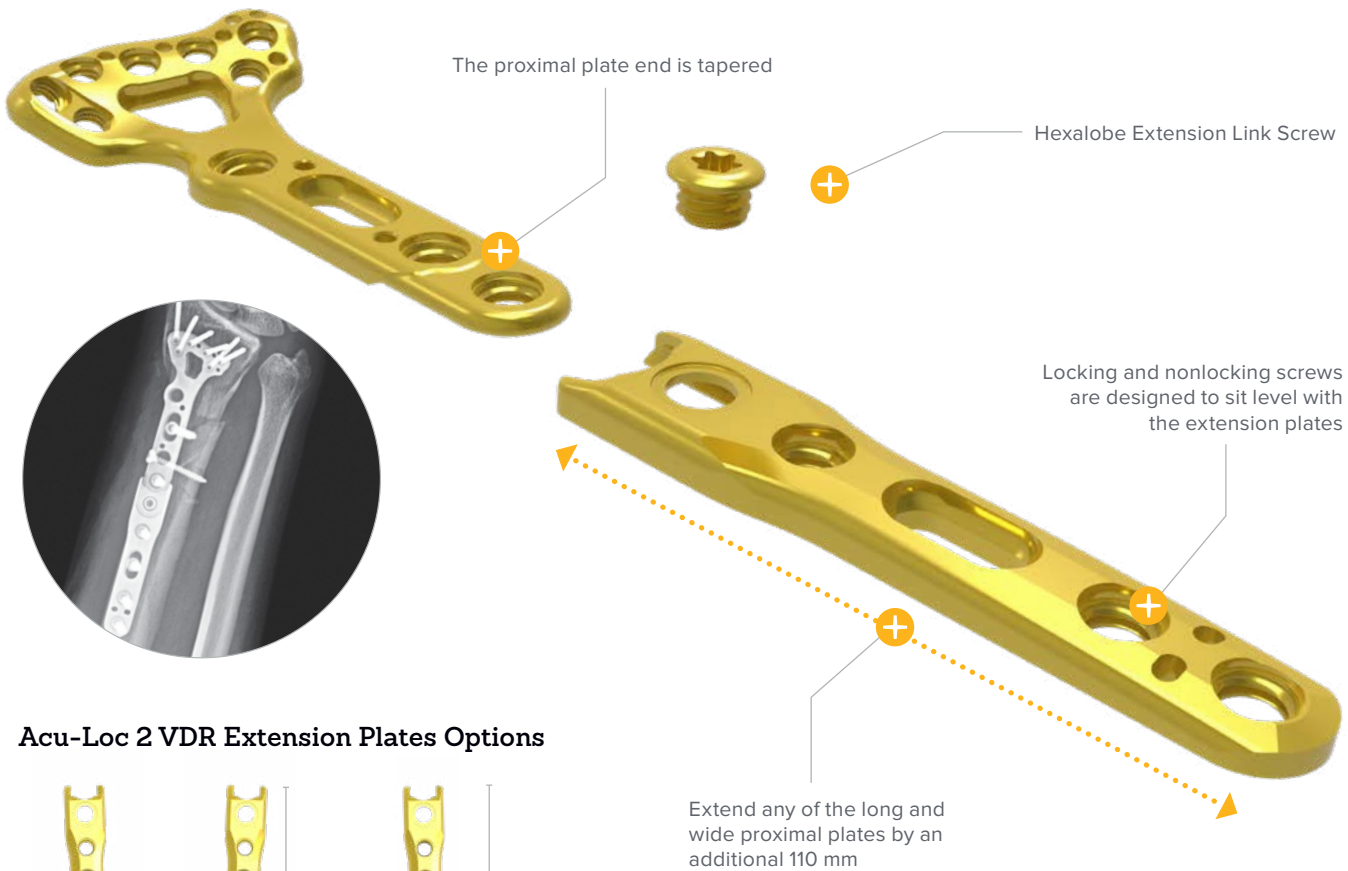

### Acu-Loc 2 VDR Extension Plates Options

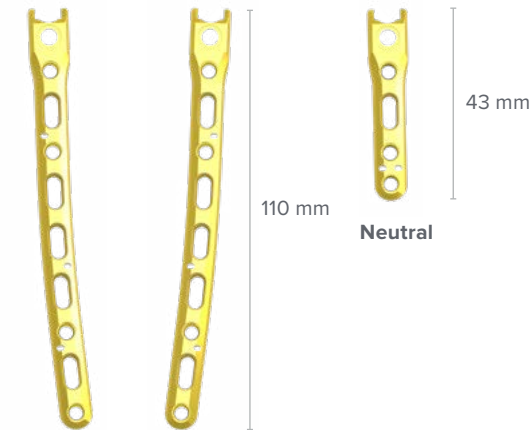

### Available Plate Length Combinations

Plate Lengths with Extension	Wide	Narrow Long	Standard Long
Neutral Extension	100 mm	108 mm	108 mm
Long Extension	167 mm	176 mm	176 mm

# System Features [continued]

## Distal Radius Fragment Specific (DRFS) Plates

The Distal Radius Fragment Specific (DRFS) Plates are designed to independently address the inherent challenges of complex fractures. Fragment-specific plating is based on the three-column model that separates the ulnar and radial sides of the distal radius from the distal ulna. The three-column theory corresponds with the most common distal radius fracture patterns and enables anatomic reconstruction of intra-articular fracture fragments.



### Volar Lunate Suture Plate

The Volar Lunate Suture Plate (70-0334) supports the volar ulnar corner of the radius. Sutures may be placed through the volar capsule and suture holes in the plate for fixation of these very small, but clinically important, bone fragments.



### Divergent Radial Styloid Plate

The Divergent Radial Styloid Plate (70-0331) buttresses the radial column. Two unicortical distal screws diverge to provide subchondral bone support, with one screw targeting the dorsal rim of the sigmoid notch and the other targeting the volar rim.



### Dorsal Lunate and Dorsal Rim Buttress Plates

Used for stabilizing fracture patterns that involve the dorsal lunate facet of the distal radius and the sigmoid notch, the Dorsal Lunate Plate (70-0337 or 70-0338) provides support to the lunate facet. The Dorsal Rim Buttress Plate (70-0335 or 70-0336) is positioned on the dorsal ulnar side of the radius and extends radially to support dorsal rim comminution and the radial styloid. A screw can be inserted ulnar-to-radial for further radial styloid support.

**Note:** If the long ulnar-to-radial styloid screw is desired in the dorsal rim buttress plate, it is recommended to use the 2.0 mm Locking Drill Guide 6–46 mm (80-0592).



### Distal Radius Fragment Specific (DRFS) Plates Options

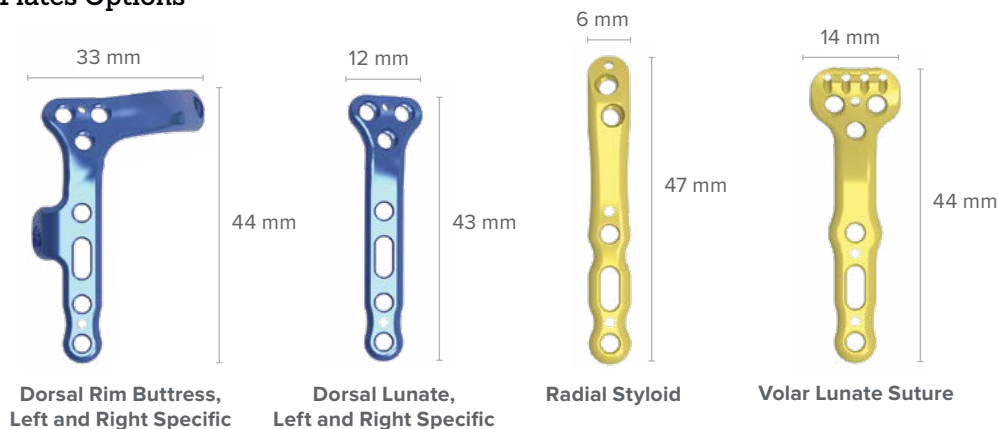

DRFS Plate Reference Chart	
Gold	Neutral
Blue	Left-specific
Green	Right-specific

# System Features [continued]

## Distal Radius Fragment Specific (DRFS) Plates

### Acu-Loc Dorsal Plates

The locking Acu-Loc Dorsal Plates offer a solution to treat distal radius fractures that need to be addressed from the dorsal side.



## Acu-Loc® Volar Distal Ulna (VDU) Plates

The Acu-Loc VDU Plates are designed specifically for periarticular fractures of the distal ulna. The screw positioning and angulation targets distal fragments of the ulnar head and neck.

### Acu-Loc VDU Plate Options





# System Features [continued]

## Wrist Spanning Plates

Designed to address complex distal radius fractures, these temporary fixators hold the wrist in distraction and provide ligamentotaxis while the distal radius heals.

For additional information on Acu-Loc Wrist Spanning Plates see HNW10-05.

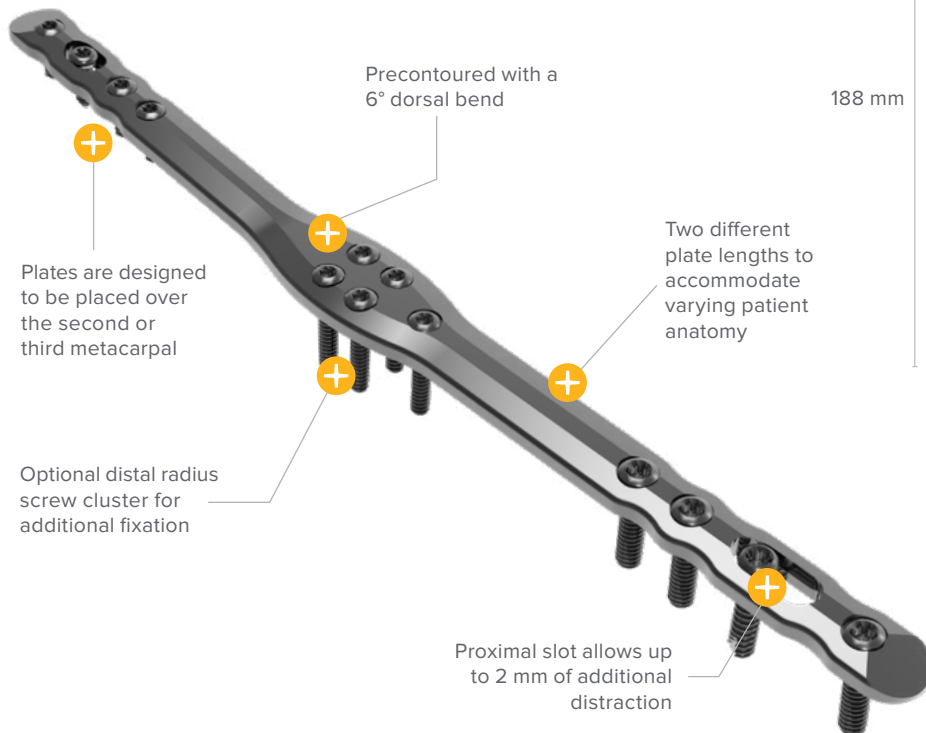

## Acu-Loc Wrist Spanning Plate Options

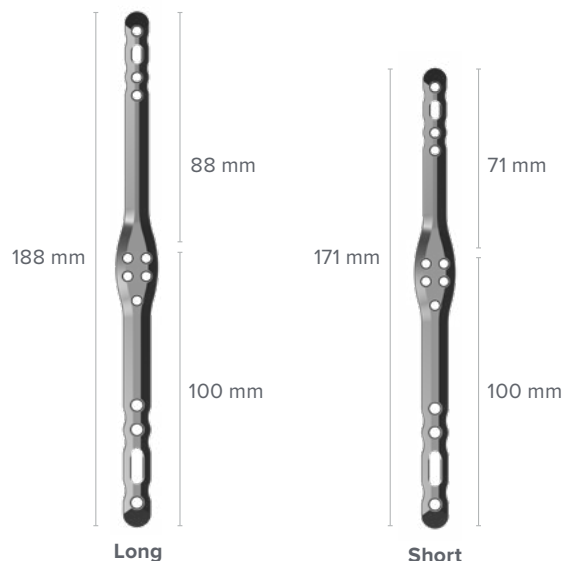

**Note:** The Acumed Acu-Loc Wrist Spanning Plate and 2.7 mm screws come sterile-packed. 2.7 mm instrumentation may be placed in the Acu-Loc 2 utility bin. The Acumed Acu-Loc 2 Wrist Plating System includes the 3.5 mm screws. Instrumentation is not included in the sterile procedure packs.

**Caution:** The Wrist Spanning 2.7 mm screws are different from the 2.7 Low-Profile Hexalobe screws.

## Acu-Loc Extra-articular (EX) Plates

All of the 2.3 mm screws in the system, including the locking variable angle screws, may be used in the distal row of the Acu-Loc EX Plates. Please see the 2.3 mm Locking Variable Angle Screw section for additional information.

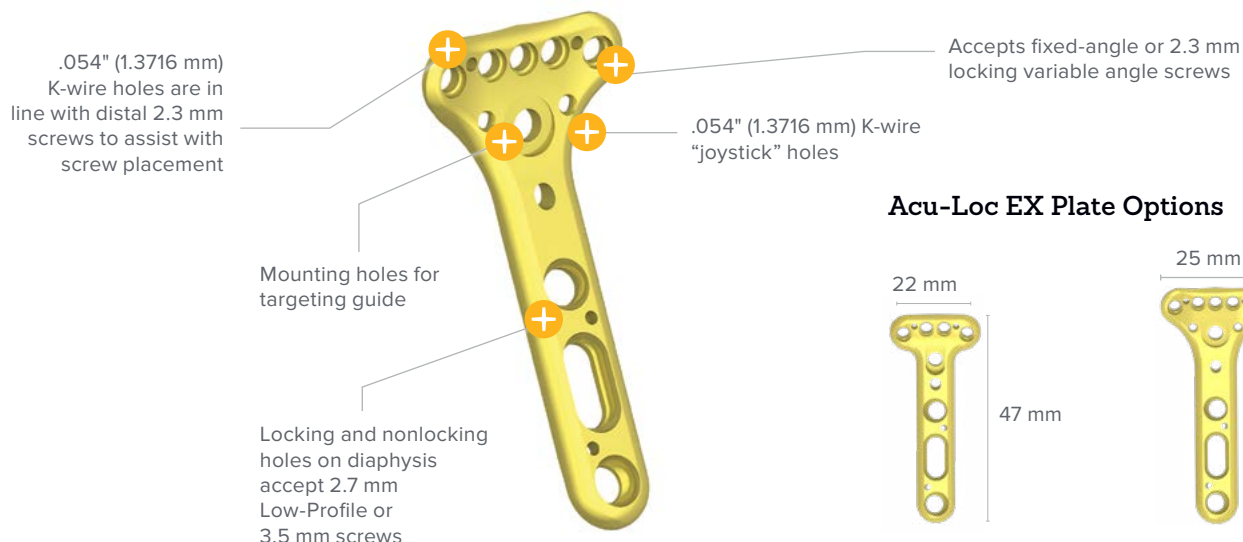

## Acu-Loc EX Plate Options

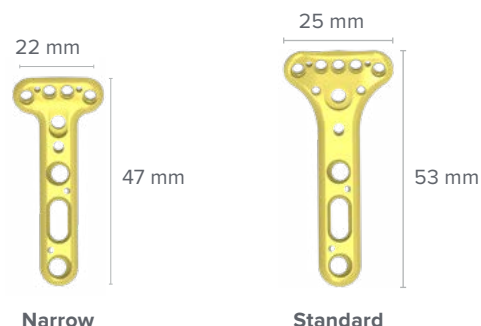

## System Features [continued]

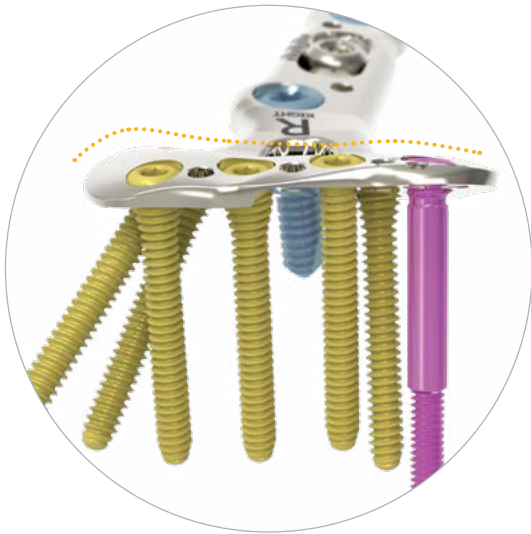

### 2.3 mm Screw Head Geometry

Reduced head geometry is designed to be level with the thinner plate design of the Acu-Loc 2 Volar Distal Radius Plates.

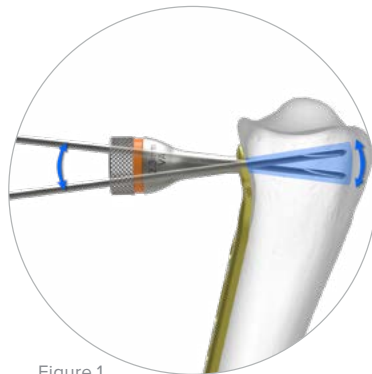
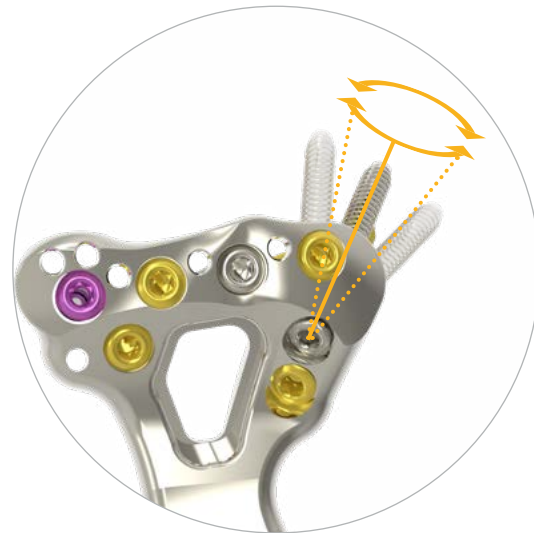

Figure 1

### 2.3 mm Locking Variable Angle Screw

The Acumed 2.3 mm Locking Variable Angle Screws (30-23XX) can be used in any distal hole of any of the gold-colored Acu-Loc 2 VDR Proximal Plates and Acu-Loc EX Plates. The 2.3 mm Locking Variable Angle Screws can also be used in the silver-colored Acu-Loc 2 VDR Plates, but only in the distal styloid hole. The 2.3 mm locking variable angle screw size options are 14–28 mm in 2 mm increments. The locking variable angle screws allow for a total variance of 15°. Locking variable angle screws are designed to aid in the capture of specific fragments or to accommodate variations in patient anatomy.

**Note:** The locking variable angle screw technology should not be used to compensate for suboptimal plate positioning and fracture reduction.

A conical 2.3 mm Variable Angle Drill Guide (80-0762) enables the surgeon to drill within the suggested 15° boundary (Figure 1). Fixed-angle radiolucent targeting guides come standard.

The locking variable angle screw instrumentation is color-coded orange to allow for quick identification of the proper drill, drill guide, and driver handle in the system.

**Caution:**

The 2.3 mm locking variable angle screws should only be used in the distal styloid hole in the silver-colored Acu-Loc 2 VDR Plates and not in any of the other distal holes in the plate.

## System Features [continued]

### Frag-Loc® Compression Screw



**Frag-Loc Compression Sleeve**  
(30-0370)



**Frag-Loc Compression Screw**  
(30-0371)



**Frag-Loc Compression Screw, Long**  
(30-0372)



The Frag-Loc Compression Screw is a two-part cannulated compression screw designed to reduce dorsal fragments to the Acu-Loc 2 VDR Plates, Distal Radius Fragment Specific (DRFS) Plates, Volar Lunate Suture Plate, Acu-Loc VDR Plates, and Acu-Loc EX Plates.

**Note:** The Frag-Loc Compression Screw may only be used for screw lengths of 16–24 mm, and the long Frag-Loc Compression Screw may be used for lengths of 20–28 mm.

A second 2.3 mm screw may be placed in an adjacent screw hole to prevent rotation of the dorsal bone fragment.



## System Features [continued]

### Key Instruments

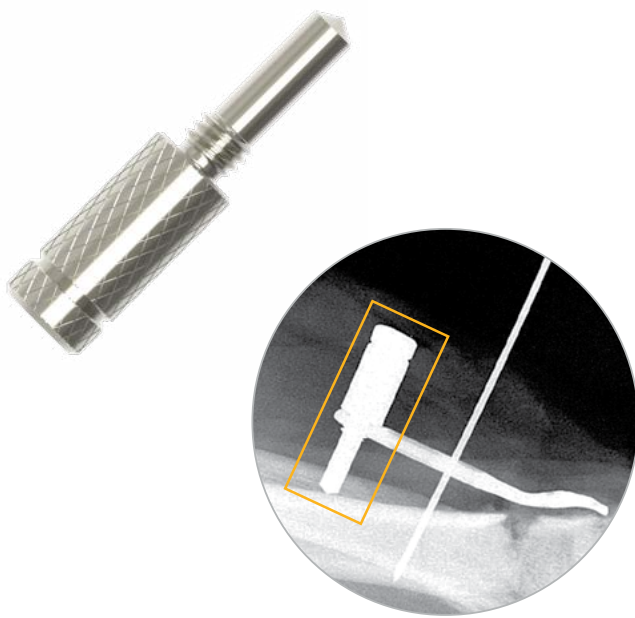

#### Acu-Loc 2 KickStand Posts

With the introduction of the next generation of distal radius fixation, the Acu-Loc 2 System offers a variety of innovative instrumentation. The KickStand Posts (80-07XX) are threaded posts designed to assist with distal radius volar tilt correction by lifting the proximal end of the plate away from the radial shaft to form a stable platform with which to achieve distal screw fixation.

Six different KickStand post angles are offered to assist with corrective osteotomies and dorsally displaced fractures. Five of the KickStand posts are offered in fixed increments of 5°, 10°, 15°, 20°, and 25° osteotomy angles. A fully threaded option for fractures allows for volar tilt correction between 5 and 30 degrees.

During an osteotomy, the desired angular correction of the volar aspect of the distal radius determines which KickStand post is selected. A 10° KickStand post will lift the plate approximately 7.5 mm. The chosen KickStand post is threaded into the locking hole just proximal of the adjustment slot of the Acu-Loc 2 VDR Plate prior to plate placement.

**KickStand Post 5°**  
(80-0718)



**KickStand Post 10°**  
(80-0719)



**KickStand Post 15°**  
(80-0720)



**KickStand Post 20°**  
(80-0721)



**KickStand Post 25°**  
(80-0722)



**KickStand Post 5–30°**  
(80-0731)





# System Features [continued]

## Key Instruments

### Targeting Guide with Radiopaque Markers

The cannulated locking bolt accepts the 2.0 mm Quick Release Drill, which is available across multiple Acumed product lines. Also available: a 50 mm-long optional cannulated locking bolt

Radiopaque Positioning Posts (Distal Row) are designed to allow visualization of the distal row screws' trajectory without K-wire placement

Multiple locking bolt positions provide the ability to insert the locking bolt into any of the distal 2.3 mm screw holes of the plate

Radiopaque Positioning Post (Radial Styloid) is designed to assist with positioning of the plate prior to K-wire and screw fixation. Under fluoroscopy, it shows the trajectory of the distal radial styloid screw prior to plate placement without drilling or K-wire placement

The fracture visualization window is designed to allow access to the fracture through the targeting guide

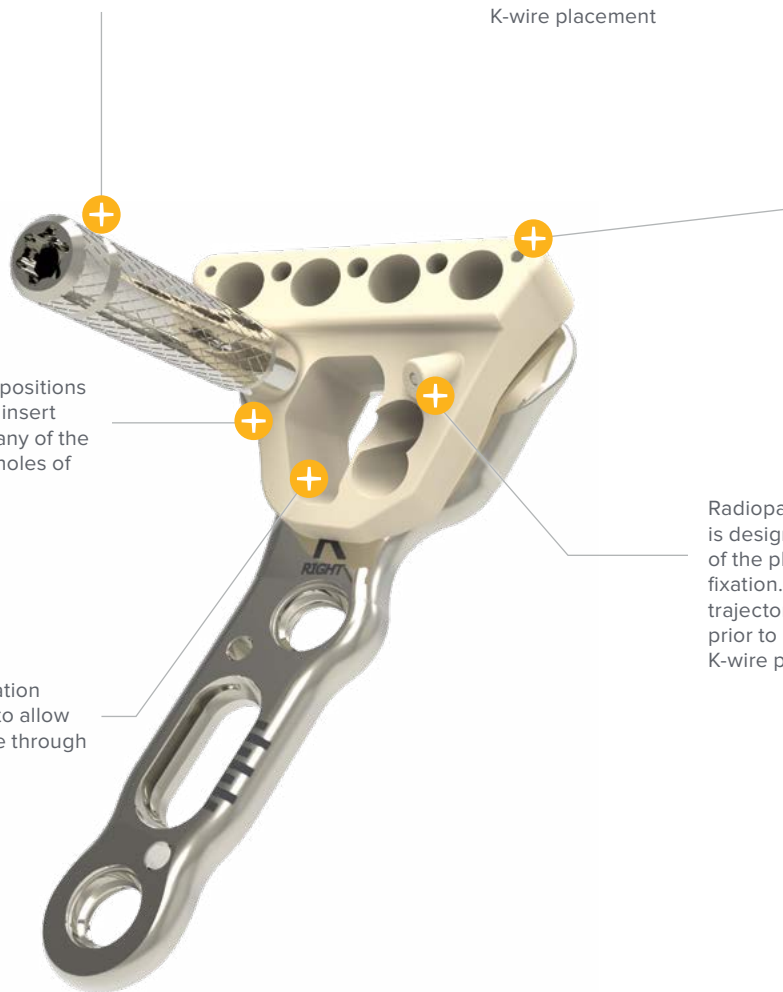

A styloid guide wire guide allows insertion of a K-wire into the radial styloid to check plate positioning before final radial styloid screw placement

# Plate Placement Instrumentation

## Acu-Loc® 2 Volar Distal Radius (VDR) Targeting Guides

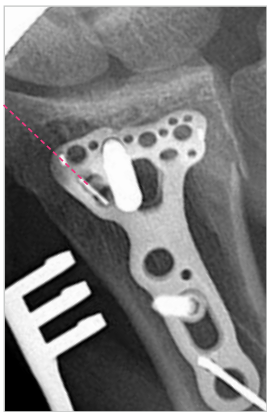

Figure 1A



Figure 1B

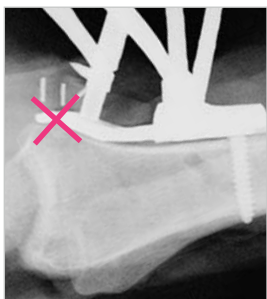

Figure 2A  
Incorrect Placement

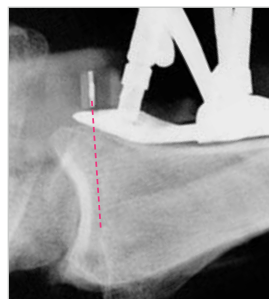

Figure 2B  
Correct Placement

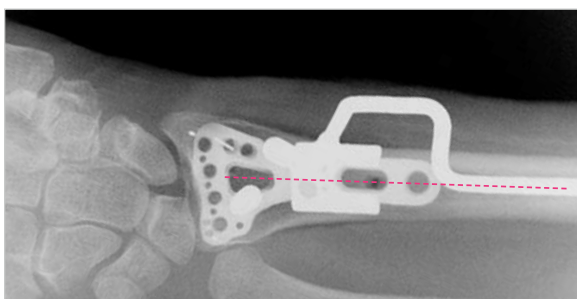
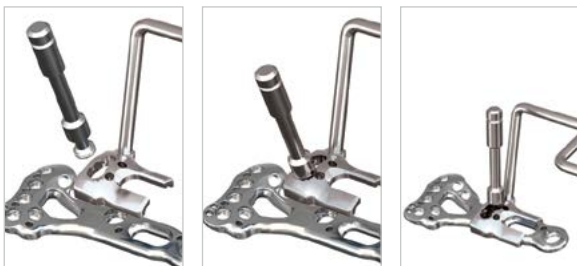

Figure 3



The low-profile radiolucent targeting guides allow the surgeon to target and insert all distal screws. Radiopaque positioning posts have been integrated into the targeting guides to assist with plate placement under fluoroscopy.

### Styloid Positioning Post (Figures 1A and 1B):

To verify plate placement, a radiopaque styloid post is utilized in an anteroposterior (A/P) view to project the trajectory of the most distal styloid screw. To align styloid screw placement, position the wrist under fluoroscopy in an A/P view and adjust the plate so that the positioning post targets the styloid tip. This verifies correct trajectory of the styloid screw prior to drilling.

**Note:** The .054" x 6" K-wire (WS-1406ST) can also be used to verify styloid screw trajectory by inserting the .054" K-wire into the .054" K-wire Guide (80-0688) through the targeting guide screw holes.

### Distal Screw Placement (Figures 2A and 2B):

To verify plate placement from a lateral view, line up the two parallel radiopaque posts. A single plane is created by the goal posts beneath the subchondral bone, showing trajectory of the distal screw row. If the posts do not target into the joint, then the distal screw row will not either. The correct trajectory can be achieved by lifting the hand in neutral rotation so that the forearm is 20 degrees to the surgical table.

The distal K-wire holes in the targeting guides and Acu-Loc 2 VDR plates allow placement of K-wires to also verify plate placement. The K-wire holes are in line with the distal screws of all Acu-Loc 2 VDR plates, allowing the surgeon to verify screw placement.

The plate's position can then be secured proximally with a .054" x 6" K-wire or Plate Tack (PL-PTACK) and distally with a .054" x 6" K-wire.

## VDR Plate Positioning Handle

The VDR Plate Positioning Handle (80-0729) (Figure 3) assists with Acu-Loc 2 VDR plate placement while keeping the surgeon's hands out of the fluoroscopy beam. Under fluoroscopy, the handle should line up with the center of the plate and radial shaft to show a true A/P view. This is used to help accurately place the proximal shaft of the plate in alignment with the center axis of the radial diaphysis.

**Note:** The design of the Acu-Loc 2 Plate Positioning Handle maintains access to the K-wire holes and 3.5 mm screw slot on the proximal end of the Acu-Loc 2 VDR plate.

## VDR Plate Positioning Handle Assembly

- ▶ The Locking Bolt 10–32 (80-0738) is threaded into the left side of the keyhole of the plate positioning handle base.
- ▶ Once engaged, the locking bolt toggles to fit left and right plates.
- ▶ Thread the locking bolt into the most distal 3.5 mm locking hole on the shaft of any Acu-Loc 2 VDR plate.

# Instrument Overview

## Frag-Loc® Instrumentation



**Frag-Loc 2.5 mm Drill Guide**  
(80-0730)



**Frag-Loc 1.5 mm Cannulated Driver**  
(80-0758)



**Frag-Loc 2.5 mm Drill**  
(80-0724)



**Frag-Loc Depth Gauge**  
(80-0726)



**Frag-Loc Compression Sleeve**  
(30-0370)

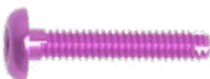

**Frag-Loc Compression Screw**  
(30-0371)



**Frag-Loc Compression Screw, Long**  
(30-0372)



**Heiss Retractor**  
(80-0756)

---

**.035" x 5.75" ST Guide Wire (K-wire)**  
(WS-0906ST)

## Variable Angle Instrumentation



**1.7 mm Quick Coupler Semi-fluted Drill**  
(80-0868)



**2.3 mm Variable Angle Drill Guide**  
(80-0762)



**Mini-AO Torque Limiting Driver, 10 in-lb**  
(80-1008)



**2.3 mm Variable Angle Drill Guide Driver**  
(80-0763)



**2.3 mm Screw Depth Gauge 6–46 mm**  
(80-1356)

## 2.7 mm Low-Profile Hexalobe Screw Instrumentation



**2.0 mm Hexalobe Locking Drill Guide 6–26 mm**  
(80-4029)



**T8 Stick Fit Hexalobe Driver**  
(80-0759)

## Instrument Overview [continued]

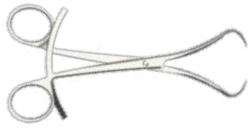

**8" Bone Reduction Forceps**  
(MS-1280)

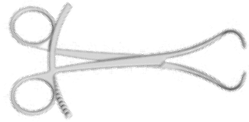

**Bone Reduction Forceps 6 3/4"**  
(80-0723)



**15 mm Hohmann Retractor**  
(MS-46827)



**VDR Plate Positioning Handle Assembly**  
(80-0729)



**Periosteal Elevator 7.5" x 6 mm Straight Edge**  
(80-0693)



**Sharp Hook**  
(PL-CL06)



**Fragment Reduction Tool**  
(80-0725)



**Plate Tack**  
(PL-PTACK)



**1.5 mm Easyout, Quick Release**  
(80-0598)



**2.5 mm Easyout, Quick Release**  
(80-0600)



**.054" x 6" Guide Wire (K-wire)**  
(WS-1406ST)



**Medium Ratcheting Driver Handle**  
(80-0663)



**2.0 mm / 2.8 mm Thin Drill Guide**  
(PL-2118)



**Depth Gauge 6-65 mm**  
(80-0623)



**Cruciform Driver Handle**  
(MS-2210)



**Acu-Loc 2 VDR Targeting Guide Locking Bolt**  
(80-0682)



**Acu-Loc 2 VDR Targeting Guide Narrow, Left**  
(80-0697)



**Acu-Loc 2 VDR Targeting Guide Standard, Left**  
(80-0695)



**Acu-Loc 2 VDR Targeting Guide Wide, Left**  
(80-0699)



**Acu-Loc 2 VDR Targeting Guide Wide, Right**  
(80-0698)



**Acu-Loc 2 VDR Targeting Guide Standard, Right**  
(80-0694)



**Acu-Loc 2 VDR Targeting Guide Narrow, Right**  
(80-0696)



**Acu-Loc 2 VDR Proximal Targeting Guide Narrow, Left**  
(80-0703)



**Acu-Loc 2 VDR Proximal Targeting Guide Standard, Left**  
(80-0701)



**Acu-Loc 2 VDR Proximal Targeting Guide Wide, Left**  
(80-0705)



**Acu-Loc 2 VDR Proximal Targeting Guide Wide, Right**  
(80-0704)



**Acu-Loc 2 VDR Proximal Targeting Guide Standard, Right**  
(80-0700)



**Acu-Loc 2 VDR Proximal Targeting Guide Narrow, Right**  
(80-0702)



## Instrument Overview [continued]



**Acu-Loc Dorsal Plate Targeting Guide Narrow, Left**  
(80-0154)



**Acu-Loc Dorsal Plate Targeting Guide Standard, Left**  
(80-0150)



**Acu-Loc Dorsal Targeting Guide Standard, Right**  
(80-0151)



**Acu-Loc Dorsal Targeting Guide Narrow, Right**  
(80-0155)



**Acu-Loc EX Targeting Guide Standard**  
(80-0166)



**Acu-Loc EX Targeting Guide Narrow**  
(80-0274)



**Locking Screw, Acu-Loc Radiolucent Targeting Guide**  
(80-0038)



**2.8 mm Quick Release Drill**  
(80-0387)



**2.0 mm Locking Drill Guide 6-46 mm**  
(80-0592)



**2.3 mm Bone Tap**  
(80-0362)



**2.8 mm Hexalobe Locking Drill Guide 6-65 mm**  
(80-0668)



**T15 Stick Fit Hexalobe Driver**  
(80-0760)



**2.3 mm Screw Sleeve, Locking Tab**  
(80-0727)



**1.5 mm Hex Driver Tip, Locking Groove**  
(80-0728)



**2.0 mm Locking Drill Guide 4-32 mm**  
(80-0249)



**.054" K-wire Guide**  
(80-0688)



**Drill Guide / Depth Gauge for 2.0 mm Drill**  
(MS-DG23)



**Distal Radius Probe**  
(MS-DRPB)



**2.0 mm Quick Release Drill**  
(80-0318)



**Small Plate Bender**  
(80-0363)

### Optional



**2.8 mm x 5" Quick Release Drill**  
(80-2008)



**2.8 mm Locking Drill Guide 6-26 mm**  
(80-2006)



**3.5 mm Locking Screw Bone Tap**  
(80-2126)



**Acu-Loc 2 VDR Targeting Guide Locking Bolt, Long**  
(80-1071)

# Surgical Technique Overview

## Acu-Loc 2 Volar Distal Radius (VDR) Surgical Technique

Exposure



Fracture Reduction



Plate Selection and Placement



Incision and Dissection



Plate Placement



## Radial Styloid Plate Surgical Technique

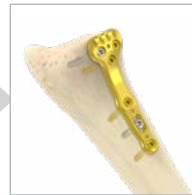

## Volar Lunate Suture Plate Surgical Technique



## Dorsal Lunate Plate and Dorsal Rim Buttress Plate Surgical Technique

Minimally Invasive Technique

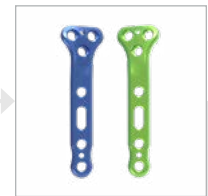

Incision and Dissection



Provisional Fixation and Plate Placement



Nonlocking Proximal Screw Placement



Drill Distal Screw Holes



## Acu-Loc Volar Distal Ulna (VDU) Plate Surgical Technique

Proximal Screw Placement



Distal Screw Holes

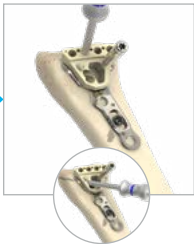

Proximal Screw Placement



Closure and Postoperative Protocol



Distal Screw Placement

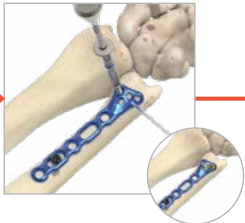

Proximal Screw Placement



Closure and Postoperative Protocol



# Surgical Technique Overview

## Acu-Loc Dorsal Plate Surgical Technique

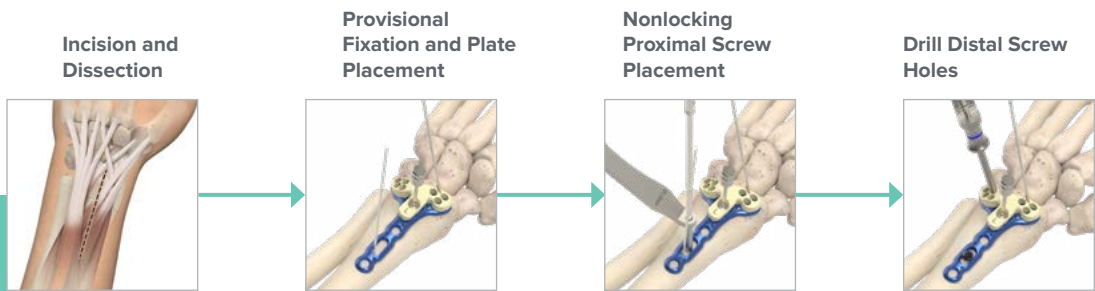

## Acu-Loc Extra-Articular (EX) Plate Surgical Technique

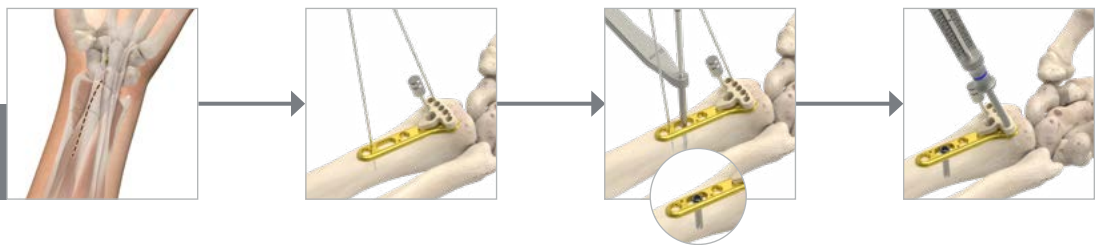

## Frag-Loc® Compression Screw Surgical Technique

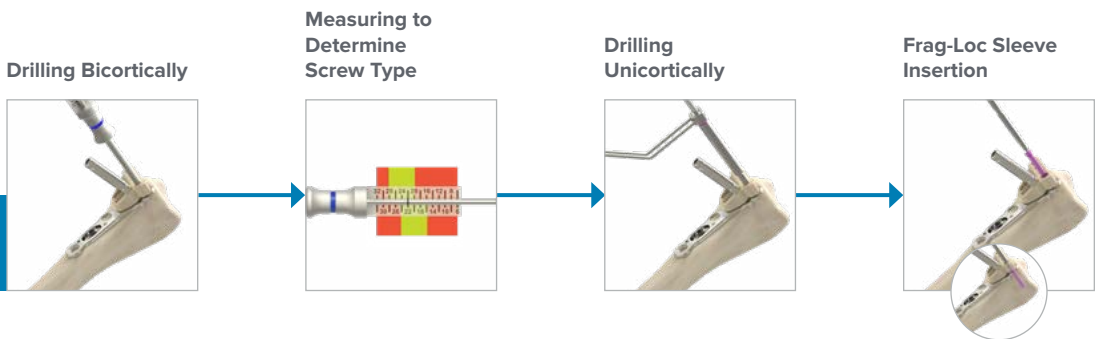

## 2.3 mm Locking Variable Angle Screw Surgical Technique

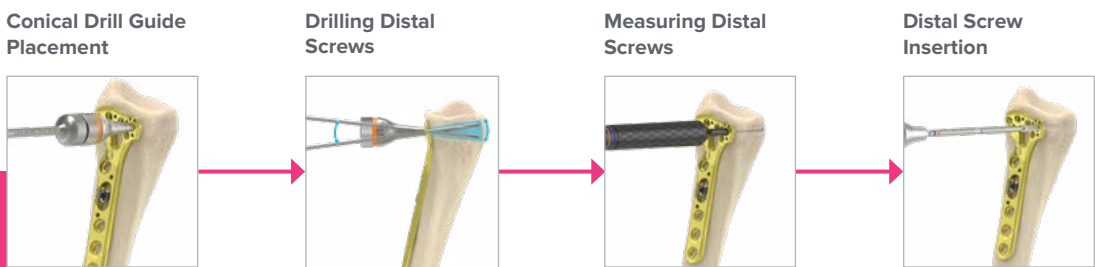

## Volar Ulnar Corner Fixation





**Distal Screw Placement**

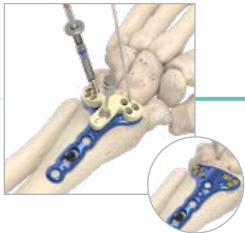

**Proximal Screw Placement**

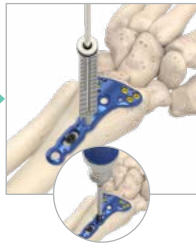

**Closure and Postoperative Protocol**

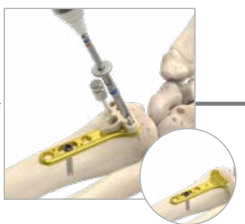

**Guide Wire (K-wire) Insertion**



**Frag-Loc® Wire Insertion**

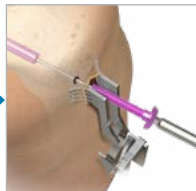

**Final Confirmation**

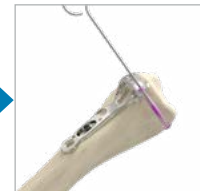

# Acu-Loc 2 Volar Distal Radius (VDR) Surgical Technique

William B. Geissler, MD  
 David S. Ruch, MD  
 Mr. Daniel J. Brown, FRCS

## Acu-Loc 2 Plate Reference Chart

<b>Silver-Colored</b>	VDR Plates offer more distal coverage and subchondral support
<b>Gold-Colored</b>	VDR Proximal Plates are designed to sit approximately 2 mm more proximal than the Standard Plates

**Note:** During bone screw insertion, the surgeon should avoid using excessive force that may result in stripping/damaging screws or driver tip. Proper observation of bone quality, patient size, and screw size can help determine the appropriate insertion torque during screw advancement and final tightening.

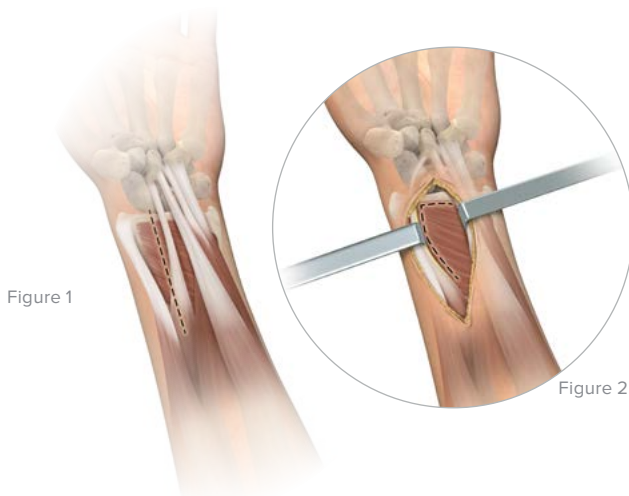

Figure 1

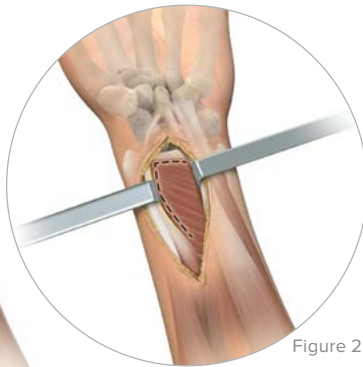

Figure 2

## 1 Exposure

Supinate the patient's forearm to expose the surgical site. To maximize exposure, place a towel under the wrist, supporting it in extension. Make a longitudinal incision approximately 6 cm in length just radial to the flexor carpi radialis (FCR) tendon to protect against injury to the palmar cutaneous branch of the median nerve (Figure 1).

Open the sheath and retract the FCR tendon radially to protect the radial artery. Identify the flexor pollicis longus (FPL) muscle by passive flexion / extension of the thumb interphalangeal joint and retract ulnarly to protect the median nerve (Figure 2). Next, identify the pronator quadratus by its transverse fibers and release radially to ulnarly to expose the fracture site.

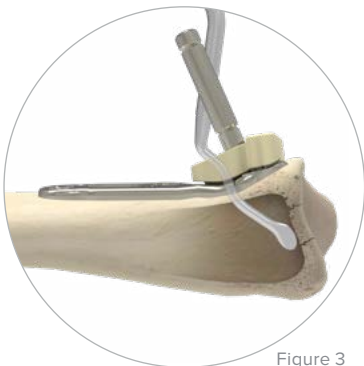

Figure 3



Figure 4



Figure 5

## 2 Fracture Reduction

The brachioradialis may need to be released from its insertion on the radial styloid to facilitate reduction and visualization of the fracture. Reduce the fracture using manual techniques. Provisional stability can be achieved with K-wires and evaluated under fluoroscopy.

### Fragment Reduction Tool (80-0725):

Use this tool for articular reconstruction (Figure 3). A broad mallet (Figure 4) and narrow thin tip (Figure 5) provide some ability to lift and position articular fracture fragments through the plate window.



Fragment Reduction Tool (80-0725)

# Acu-Loc 2 Volar Distal Radius (VDR) Surgical Technique [continued]

## 3 Plate Selection and Placement

The Acu-Loc 2 VDR Plate (70-03XX) is made to sit along the distal aspect of the radius to support articular fracture fragments (Figure 6). There are two volar plate families to select from: the Acu-Loc 2 VDR Standard Plates and the Acu-Loc 2 VDR Proximal Plates, which are designed to sit 2 mm more proximal than the standard plates. If a longer plate is needed, choose the appropriate Acu-Loc 2 VDR Extension Plate (70-0364, 70-0365, 70-0366) and assemble as described below. The Acu-Loc 2 VDR Extension Plates (70-0364, 70-0365, 70-0366) should be implanted using 3.5 mm Hex or Hexalobe Screws (30-02XX or CO-31XX).

Once the appropriate-size plate is selected, attach the corresponding Acu-Loc 2 VDR Targeting Guide (80-06XX or 80-07XX) using the Acu-Loc 2 VDR Targeting Guide Locking Bolt (80-0682) or the optional Targeting Guide Locking Bolt, Long (80-1071) (Figure 7). Thread the cannulated locking bolt into the proximal ulnar 2.3 mm screw hole. The plate should be placed parallel to the radial shaft.

For styloid and distal screw placement using the patented markers in the targeting guides, refer to Plate Placement Instrumentation on page 12.

### Extension Plate Assembly Steps

Slide the desired Acu-Loc 2 Extension Plate (70-0364, 70-0365, 70-0366) onto the shaft of the Acu-Loc 2 Proximal Plate.

Using a 2.5 mm Quick Release Hex Driver (HPC-0025) or a T15 Stick Fit Hexalobe Driver (80-0760), insert and tighten the Hex or Hexalobe Acu-Loc 2 VDR Extension Link Screw (30-0XXX) into the distal hole of the extension plate, and lock into both plates.

Assembly can be done prior to plate placement or intraoperatively.

**Warning:** The 2.7 mm Low-Profile Hexalobe Screw is not designed to be used with the Acu-Loc 2 Extension Plate (70-0364, 70-0365, 70-0366).



Figure 7

Figure 6

### Available Plate-Length Combinations

Plate Lengths with Extension	Wide	Narrow Long	Standard Long
Neutral Extension	100 mm	108 mm	108 mm
Long Extension	167 mm	176 mm	176 mm

**Note:** The VDR Plate Positioning Handle (80-0729) can be used at this time for plate placement. Refer to Plate Placement Instrumentation on page 12 for assembly and technique.



Acu-Loc 2 VDR Extension Plate (70-036X)



Acu-Loc 2 VDR Targeting Guide (80-06XX or 80-07XX)



Acu-Loc 2 VDR Targeting Guide Locking Bolt (80-0682)



Targeting Guide Locking Bolt, Long (80-1071)



2.5 mm Quick Release Hex Driver (HPC-0025)



T15 Stick Fit Hexalobe Driver (80-0760)



Acu-Loc 2 VDR Extension Link Screw (30-0XXX)



VDR Plate Positioning Handle (80-0729)

# Acu-Loc 2 Volar Distal Radius (VDR) Surgical Technique [continued]

Figure 8



## 4 Proximal Screw Placement

The first screw to be placed is a 3.5 mm Nonlocking Hex or Hexalobe Screw (30-02XX or CO-31XX) through the slot in the plate. Using the 2.8 mm Quick Release Drill (80-0387) and the 2.0 mm / 2.8 mm Thin Drill Guide (PL-2118), drill through the far cortex. Then measure the drill depth with the Depth Gauge 6–65 mm (80-0623). Insert a 3.5 mm nonlocking hex or hexalobe screw (Figure 8). The screw may need to be downsized after the plate has been reduced down to the bone.

**Note:** An optional 3.5 mm Locking Screw Bone Tap (80-2126) may be necessary if encountering hard cortical bone.

**Optional:** A 2.7 mm Nonlocking Low-Profile Hexalobe Screw (3041-230XX) can be used in place of the 3.5 mm screw using the 2.0 mm Quick Release Drill (80-0318).

Figure 9

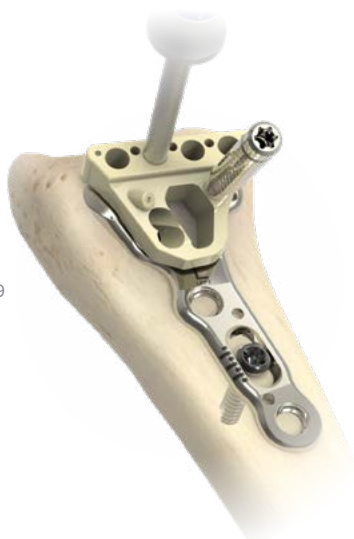

## 5 Distal Screw Holes

Utilizing the radiopaque positioning posts in the targeting guide, the position of the plate relative to the radiocarpal articular surface can be fine-tuned by sliding the plate proximally or distally, under fluoroscopy. If the radiopaque posts don't target the joint, the distal K-wires and 2.3 mm screws will not either. To further assess the position of the distal 2.3 mm screws relative to the radio-carpal articular surface, place a .054" x 6" K-wire (WS-1406ST) through one of the K-wire holes in the targeting guide closest to the joint and assess its location under fluoroscopy.

Upon satisfactory reduction and anatomic fit, insert the Drill Guide / Depth Gauge for 2.0 mm Drill (MS-DG23) into one of the distal screw holes and drill using the 2.0 mm Quick Release Drill (80-0318) (Figure 9). Measure screw length by using the laser mark on the drill or Distal Radius Probe (MS-DRPB) against the scale on the drill guide.

**Note:** Screw insertion into the proximal ulnar 2.3 mm hole should be performed after all other distal 2.3 mm screws are placed. Drilling can be performed through the Acu-Loc 2 VDR Targeting Guide Locking Bolt (80-0682). To measure screw length, remove the locking bolt and use the drill guide and depth probe, or the orange-and-blue-banded 2.3 mm Screw Depth Gauge 6–46 mm (80-1356).

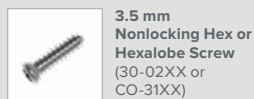

3.5 mm Nonlocking Hex or Hexalobe Screw (30-02XX or CO-31XX)



2.8 mm Quick Release Drill (80-0387)



2.0 mm / 2.8 mm Thin Drill Guide (PL-2118)



Depth Gauge 6–65 mm (80-0623)



2.7 mm Nonlocking Low-Profile Hexalobe Screw (3041-230XX)



2.0 mm Quick Release Drill (80-0318)



3.5 mm Locking Screw Bone Tap (80-2126)



.054" x 6" Guide Wire (K-wire) (WS-1406ST)



Drill Guide / Depth Gauge for 2.0 mm Drill (MS-DG23)



Distal Radius Probe (MS-DRPB)



2.3 mm Screw Depth Gauge 6–46 mm (80-1356)

# Acu-Loc 2 Volar Distal Radius (VDR) Surgical Technique [continued]

**Distal Screw Options:** The four options of 2.3 mm screws that can be used distally are fully threaded Locking Cortical Screws (gold) (CO-T23XX), Locking Cortical Pegs (bronze) (CO-S23XX), Nontoggling Cortical Screws (silver) (CO-N23XX), and the Frag-Loc® Compression Screw (30-037X). All 2.3 mm screws are inserted using the 1.5 mm Hex Driver Tip, Locking Groove (80-0728), the 2.3 mm Screw Sleeve, Locking Tab (80-0727), and the silver Cruciform Driver Handle (MS-2210).

**Caution:** The orange Torque Limiting Driver (TLD) is only validated for use when inserting the 2.3 mm Variable Angle Locking Screws. Do not use the TLD when inserting fixed angle screws as the exerted torque can accelerate the fatigue of the 1.5 mm driver tips.

**Variable Angle Screw:** 2.3 mm Locking Variable Angle Screws (30-23XX) may be used with the VDR Proximal Plates only. Refer to the 2.3 mm Locking Variable Angle Screw Reference Information on page 8 and the Surgical Technique on page 45.

**Styloid Screw Placement:** The radial styloid screws are designed to specifically target and support the radial styloid. Insert the drill guide into either styloid hole located in the dual slot on the radial side of the targeting guide and continue the same screw measurement and placement process for both styloid screws (Figure 10).

**Note:** It is recommended that the entire distal row and the two radial styloid holes be filled with screws.

**Note:** An individual 2.0 mm Locking Drill Guide 4–32 mm (80-0249) is available in the system as an alternative for drilling the distal holes. Screw length can be read using the Distal Radius Probe (MS-DRPB) or Screw Depth Gauge (80-1356).

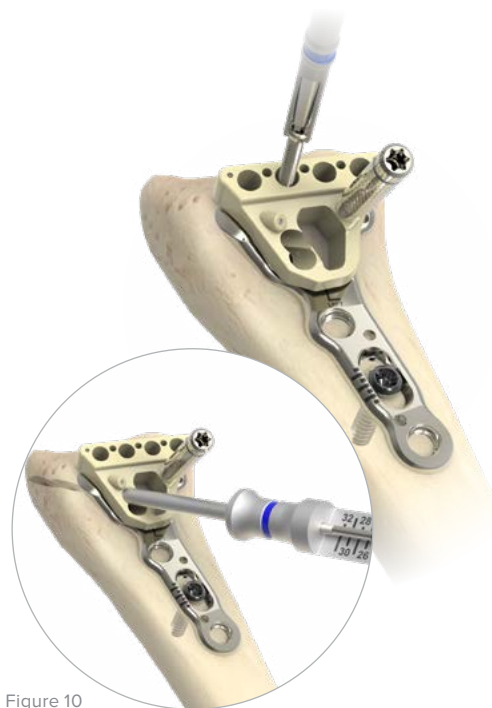
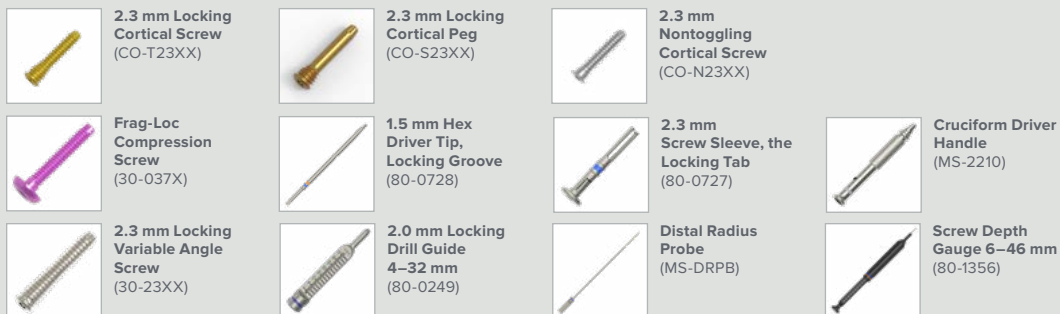

Figure 10





# Acu-Loc 2 Volar Distal Radius (VDR) Surgical Technique [continued]

Figure 11



## 6 Proximal Screw Placement

Insert the threaded 2.8 mm Locking Drill Guide (80-0384 or 80-0668) into the screw hole distal to the slot, drill with the 2.8 mm Quick Release Drill (80-0387), and measure with the Depth Gauge 6–65 mm (80-0623). Insert the proper-length 3.5 mm Locking Hex or Locking Hexalobe Screw (30-023X or COL-3XXX) (Figure 11). Take care that the screw does not exit the bone dorsally. Using the same process, drill and place the final locking screw (Figure 12).

**Note:** 3.5 mm locking or nonlocking hex or hexalobe screws can be used in the proximal round locking holes. Depending on the bone quality of the patient and at the surgeon's discretion, 3.5 mm nonlocking hex or hexalobe screws may be preferred for use in the round locking holes.

An optional 3.5 mm Locking Screw Bone Tap (80-2126) may be necessary if encountering hard cortical bone.

**Optional:** A 2.7 mm Locking Low-Profile Hexalobe Screw (3040-230XX) can be used in place of the 3.5 mm screw using the 2.0 mm Quick Release Drill (80-0318) and the 2.0 mm Hexalobe Locking Drill Guide (80-4029).

Figure 12



## 7 Closing and Postoperative Protocol

Perform a thorough radiographic evaluation, checking fragment reduction, alignment, and screw placement. Verify that there is no gap between the bone and the plate in the lateral view and that the distal screws have not penetrated the radiocarpal joint (Figures 13 and 14). Close the wound and support the wrist according to bone quality and stability.

Allow for early functional use of the hand and start immediate finger range of motion and forearm rotation postoperatively.

Closing and postoperative protocol are at the discretion of the surgeon.

Figure 13

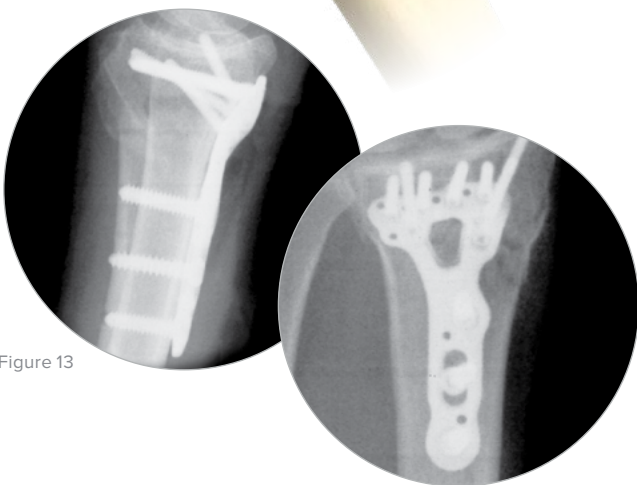

2.8 mm Locking Drill Guide (80-0384 or 80-0668)



2.8 mm Quick Release Drill (80-0387)



Depth Gauge 6–65 mm (80-0623)



Medium Ratcheting Driver Handle (80-0663)



3.5 mm Locking Hex or Locking Hexalobe Screw (30-023X or COL-3XXX)



2.7 mm Locking Low-Profile Hexalobe Screw (3040-230XX)



2.0 mm Quick Release Drill (80-0318)



2.0 mm Hexalobe Locking Drill Guide (80-4029)



3.5 mm Locking Screw Bone Tap (80-2126)

# Acu-Loc 2 Volar Distal Radius (VDR) Surgical Technique [continued]

## 8 Optional: Implant Removal Instructions

To extract an Acu-Loc 2 VDR Plate, use the 2.5 mm Hex Driver (HPC-0025) or T15 Stick Fit Hexalobe Driver (80-0760) and Medium Ratcheting Driver Handle (80-0663) to remove all the 3.5 mm screws in the plate. Use the T8 Stick Fit Hexalobe Driver (80-0759) and Medium Ratcheting Driver Handle (80-0663) to remove any 2.7 mm screws. Use the 1.5 mm Hex Driver Tip, Locking Groove (80-0728) with the Cruciform Driver Handle (MS-2210) for the 2.3 mm screws.

Referencing the Screw Removal Brochure (SPF10-00) may aid in implant extraction if difficulty is experienced.



**2.5 mm Hex Driver Tip**  
(HPC-0025)



**T15 Stick Fit Hexalobe Driver**  
(80-0760)



**Medium Ratcheting Driver Handle**  
(80-0663)



**T8 Stick Fit Hexalobe Driver**  
(80-0759)



**1.5 mm Hex Driver Tip, Locking Groove**  
(80-0728)



**Cruciform Driver Handle**  
(MS-2210)

# Distal Radius Fragment Specific (DRFS) Surgical Technique

William B. Geissler, MD

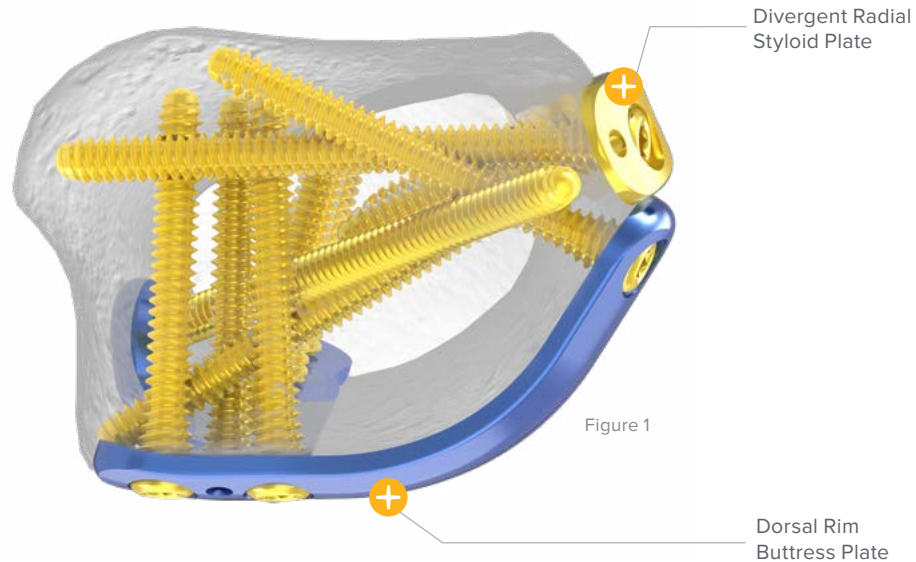

## General Technique

Once a DRFS plate is positioned, an initial 2.3 mm Nontoggling Cortical Screw (CO-N23XX) is placed into the slot on the proximal end of the plate utilizing a 2.0 mm Quick Release Drill (80-0318) and 1.5 mm Hex Driver Tip, Locking Groove (80-0728). Screw length is determined for the plate slot by utilizing the 2.3 mm Screw Depth Gauge 6–46 mm (80-1356). The plate position is evaluated under fluoroscopy.

There are three types of 2.3 mm screws that can be used in any of the threaded screw holes of the DRFS plates (see page 23 under Distal Screw Options). Screw length can be measured by using the laser mark on the drill or Distal Radius Probe (MS-DRPB) against the scale on the locking drill guide, or 2.3 mm screw depth gauge.

Due to the multi-plate approach, screws from one DRFS plate may collide with screws from another DRFS plate. Use the longest screw possible where appropriate.



DRFS Plate  
(70-033X)



2.3 mm  
Nontoggling  
Cortical Screw  
(CO-N23XX)



2.0 mm Quick  
Release Drill  
(80-0318)



1.5 mm Hex  
Driver Tip,  
Locking Groove  
(80-0728)



2.3 mm Screw  
Depth Gauge  
6–46 mm  
(80-1356)



Distal Radius  
Probe  
(MS-DRPB)

## Distal Radius Fragment Specific (DRFS) Surgical Technique [continued]

### Note:

1. The 2.3 mm Bone Tap (80-0362) should be used on the proximal holes of the DRFS plates where more cortical bone is present, making screw insertion difficult and increasing the risk of screw breakage. This is especially important in younger patients who may have thicker cortical bone in this region.
2. The 2.0 mm Locking Drill Guide 4–32 mm (80-0249) from the 2.3 mm screw caddy can be used for all locking holes on the plates EXCEPT for the ulnar-to-radial styloid screw on the dorsal rim buttress plate, which may require screws greater than 32 mm in length (see Dorsal Rim Buttress Plate Placement for drill guide information, page 28).

Figure 2

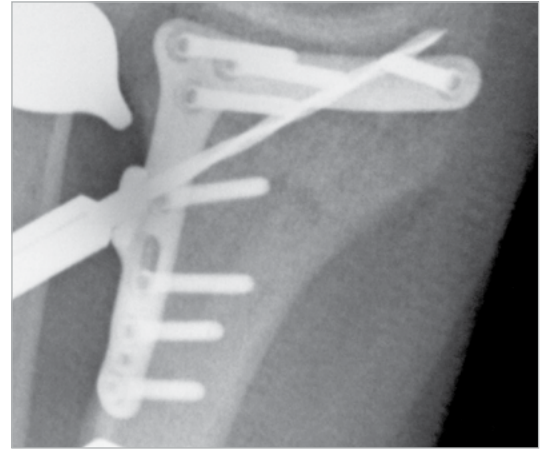

Figure 3



2.3 mm Bone Tap  
(80-0362)



2.0 mm Locking  
Drill Guide  
4–32 mm  
(80-0249)

# Radial Styloid Plate Surgical Technique

William B. Geissler, MD

Figure 1



## 1 Incision and Dissection

The Divergent Radial Styloid Plate (70-0331) may be inserted by one of two approaches. The plate may be placed on the dorsal radial aspect of the radial styloid, utilizing the standard dorsal approach.

Alternatively, the plate may be inserted through an incision between the first and second extensor compartments.

Perform blunt dissection to protect the terminal branches of the dorsal sensory branch of the radial nerve. After the branch is identified and protected, open the interval between the first and second compartments and elevate the tendons (Figure 1).

Figure 2



## 2 Plate Placement

The plate is designed to sit under the first dorsal compartment tendons (Figure 2).

**Note:** To find the screw angles more easily, place the 2.0 mm Locking Drill Guide 4–32 mm (80-0249) in line with the laser band next to the hole (Figure 3).

Figure 3



Divergent Radial Styloid Plate (70-0331)



2.0 mm Locking Drill Guide 4–32 mm (80-0249)



# Volar Lunate Suture Plate Surgical Technique

William B. Geissler, MD

## 1 Incision and Dissection

The Volar Lunate Suture Plate (70-0334) may be inserted through a standard volar flexor carpi radialis approach (refer to Acu-Loc 2 VDR Surgical Technique on page 20) (Figure 1).

Alternatively, the volar ulnar corner of the distal radius may be approached through an incision placed between the flexor tendons and the ulnar neurovascular bundle. Make an incision in line with the ring finger starting at the distal volar crease and extending proximally. Dissect down to the level of the fascia that is open in line with the incision. Identify the ulnar neurovascular bundle along the ulnar aspect of the approach and retract ulnarly. Retract the flexor tendons radially to expose the volar ulnar corner.

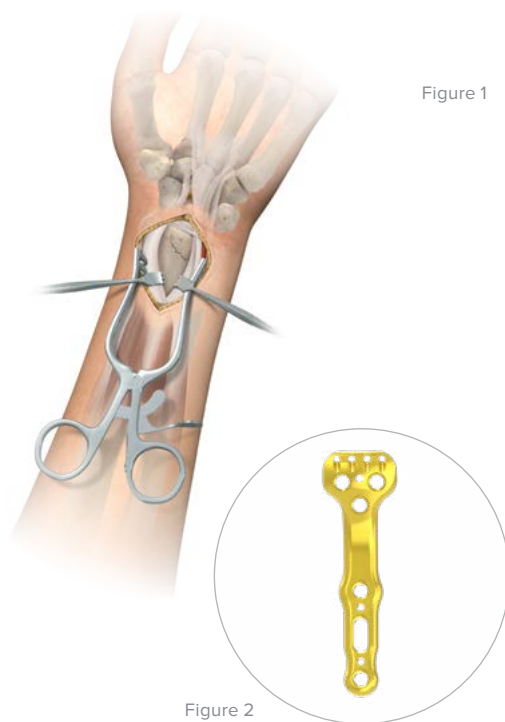

Figure 1

## 2 Plate Placement

Align the Volar Lunate Suture Plate with the medial border of the radial shaft (Figures 2 and 3).

If suture is needed to address small distal fragments, pass a suture through the capsule supporting the small articular fragments and through the distal suture holes in the plate. If necessary, a .054" x 6" K-wire (WS-1406ST) can be used to drill through the bone in order to pass the suture through the articular fragment.



Figure 2



Figure 3



Volar Lunate Suture Plate (70-0334)



.054" x 6" Guide Wire (K-wire) (WS-1406ST)

# Dorsal Lunate Plate and Dorsal Rim Buttress Plate Surgical Technique

William B. Geissler, MD

Figure 1

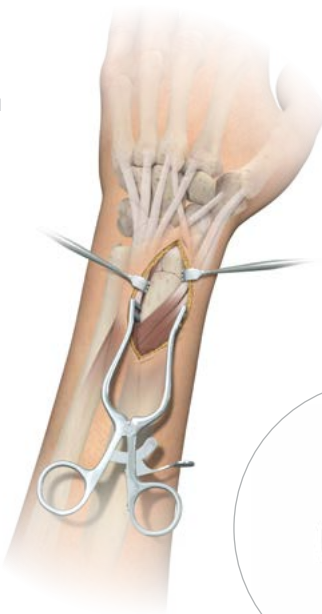

Figure 2



## 1 Incision and Dissection

Make a 6 cm incision in line with the middle finger starting just distal to Lister's tubercle and extending proximally. Carry down blunt dissection to protect the dorsal sensory branch of the radial nerve. Identify the extensor pollicis longus tendon distal in the wound and release through the third dorsal compartment. The tendon may be retracted radially or ulnarly depending on the fracture pattern.

Then subperiosteally elevate the second and fourth dorsal compartments to expose the dorsum. Ulnarly elevate the fourth dorsal compartment to the border of the distal radial ulnar joint (Figure 1).

Additional dissection is needed proximal to the distal radial ulnar joint (DRUJ) to accommodate the Dorsal Rim Buttress Plate (70-0335 or 70-0336) (Figure 2) ulnar-to-radial styloid screw which extends from just proximal to the DRUJ to the radial styloid.

Elevate the second dorsal compartment from the ulnar to radial to the level of the brachioradialis.



Figure 3

## 2 Dorsal Rim Buttress Plate Placement

If it is determined that the long ulnar-to-radial styloid screw is needed, the 2.0 mm Locking Drill Guide 6 mm–46 mm (80-0592) should be threaded into the plate prior to plate placement on bone (Figure 3). The ulnar-to-radial styloid screw hole is located on the angled plate tab next to the slot on the plate shaft.

Initially position the plate on the dorsal ulnar side of the radius. The buttress portion of the plate should be parallel to the radial inclination (Figure 4).

Figure 4



Dorsal Rim Buttress Plate (70-033X)



2.0 mm Locking Drill Guide 6 mm–46 mm (80-0592)

## Dorsal Lunate Plate and Dorsal Rim Buttress Plate Surgical Technique [continued]

### 3 Minimally Invasive Technique

Alternatively, the Dorsal Lunate Plate (70-0337 or 70-0338) (Figure 5) may be inserted through a small incision directly over the fifth compartment. Make an incision in line with the ring finger centered over the distal radius.

The interval between the fourth and fifth dorsal compartment is then elevated to expose the dorsal ulnar corner of the radius.

**Note:** Keep in mind that the distal holes on the dorsal plates that support the lunate facet are not perpendicular to the plate, but are angled toward the volar ulnar corner of the distal radius.



Figure 5



Dorsal Lunate Plate  
(70-033X)

# Acu-Loc Volar Distal Ulna (VDU) Plate Surgical Technique

William B. Geissler, MD

## Acu-Loc VDU Plate Reference Chart

<b>Blue</b>	Left-specific
<b>Green</b>	Right-specific

## 1 Incision and Dissection

The Volar Distal Ulna Plate (70-004X) was designed for fractures involving the ulnar head, ulnar neck, and fractures of the distal ulna. Usually, these injuries are associated with fractures of the distal radius. Make the incision along the distal ulnar border of the forearm between the flexor carpi ulnaris and extensor carpi ulnaris (Figure 1). Carry down blunt dissection to protect the dorsal sensory branch of the ulnar nerve, which may be seen on the volar distal portion of the incision. Retract the flexor carpi ulnaris radially and dissect the pronator quadratus off the anterior distal surface of the ulna. Identify the fracture site and clear fracture debris; then provisionally reduce.

Figure 1



## 2 Provisional Fixation and Plate Placement

Place the VDU plate on the volar surface of the distal ulna so that the four distal locking screws will be positioned to go into the ulnar head (Figure 2).

**Caution:** It is vital that the plate is placed just proximal to the lesser sigmoid notch of the distal radial ulnar joint. In this manner, the plate should not impinge with pronation and supination of the forearm.

Place a .054" x 6" K-wire (WS-1406ST) in the proximal portion of the plate. Place a second K-wire in the distal portion of the plate to provisionally hold the plate to the bone.

Figure 2

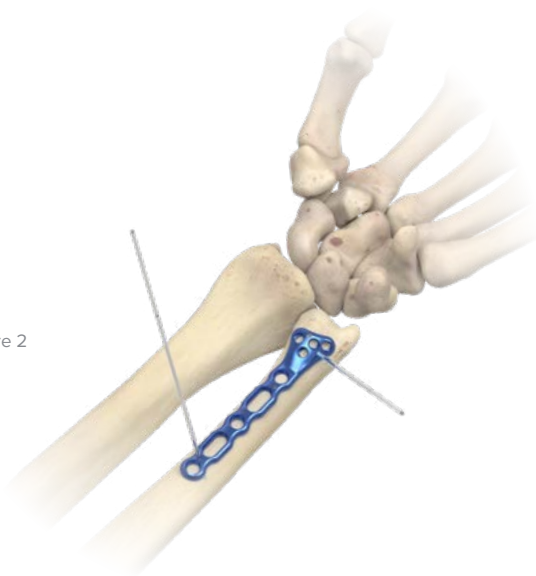

Volar Distal Ulna Plate (70-004X)



.054" x 6" Guide Wire (K-wire) (WS-1406ST)

# Acu-Loc Volar Distal Ulna (VDU) Plate Surgical Technique [continued]

## 3 Nonlocking Proximal Screw Placement

Place the first 3.5 mm Nonlocking Hex or Hexalobe Screw (30-02XX) in the center of the proximal slot in the plate.

The position of the plate relative to the articular surface can then be fine-tuned by sliding the plate proximally or distally. Using the 2.8 mm Quick Release Drill (80-0387) and 2.0 mm / 2.8 mm Thin Drill Guide (PL-2118), drill through the far cortex (Figure 3). Drill depth is measured with the Depth Gauge 6–65 mm (80-0623) (Figure 4). Insert the appropriate 3.5 mm nonlocking hex or hexalobe screw, taking care that the screw is the proper length.

**Optional:** A 2.7 mm Nonlocking Low-Profile Hexalobe Screw (3041-230XX) can be used in place of the 3.5 mm screw using the 2.0 mm Quick Release Drill (80-0318).

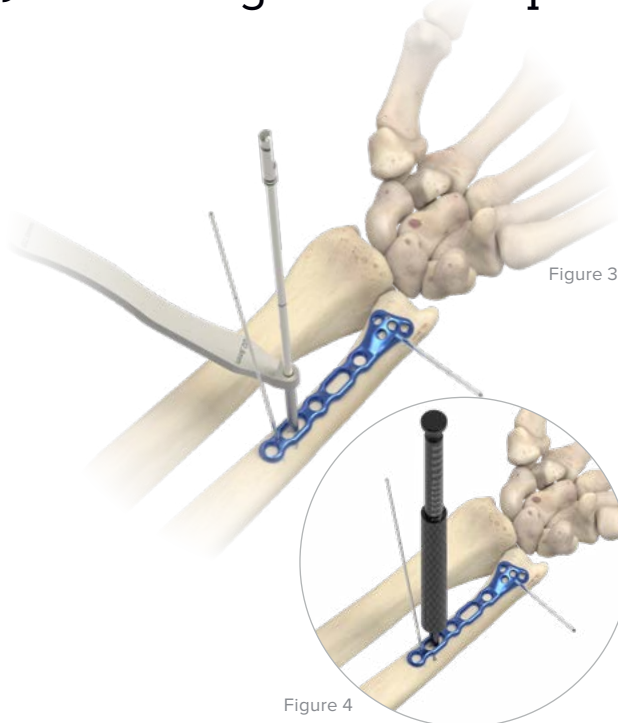

## 4 Drill Distal Screw Holes

Place the individual 2.0 mm Locking Drill Guide 4–32 mm (80-0249) in the most distal ulnar hole in the plate (Figure 5). Drill using the 2.0 mm Quick Release Drill (80-0318), then measure screw length by using the laser mark on the drill or Distal Radius Probe (MS-DRPB) against the scale on the drill guide (Figure 6).

**Note:** The locking drill guide may also be attached to the selected plate on the back table prior to insertion.

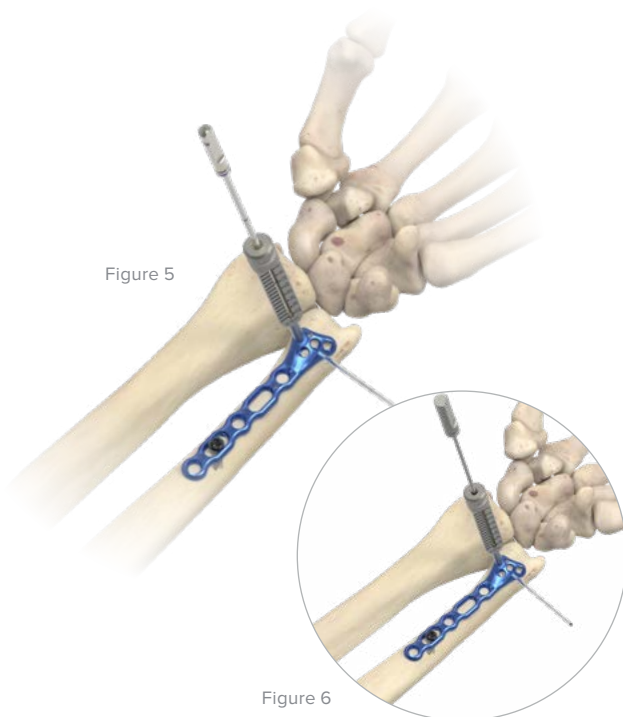



# Acu-Loc Volar Distal Ulna (VDU) Plate Surgical Technique [continued]

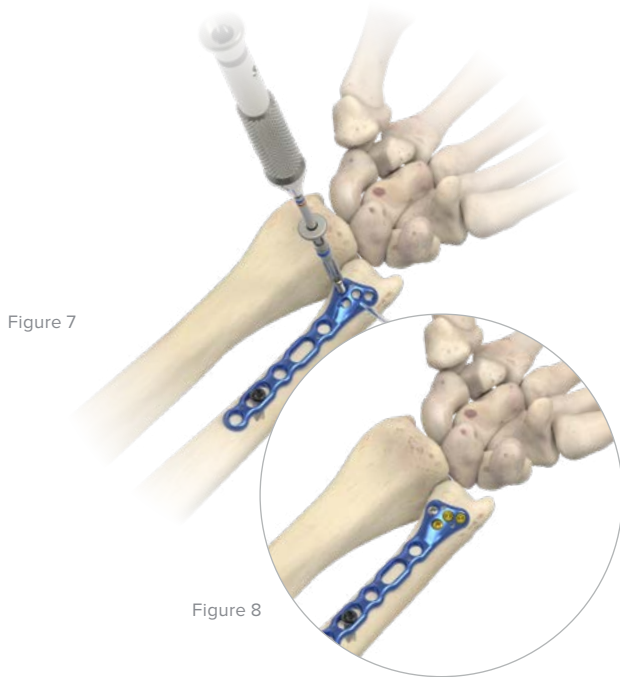

Figure 7

Figure 8

## 5 Distal Screw Placement

Three types of 2.3 mm screws can be used in any of the four distal holes: Locking Cortical Screws (gold) (CO-T23XX), Locking Cortical Pegs (bronze) (CO-S23XX), and Nontoggling Cortical Screws (silver) (CO-N23XX). All 2.3 mm screws are inserted using the 1.5 mm Hex Driver Tip, Locking Groove (80-0728), 2.3 mm Screw Sleeve, Locking Tab (80-0727), and the silver Cruciform Driver Handle (MS-2210) (Figures 7 and 8).

## 6 Proximal Screw Placement

Thread the threaded 2.8 mm Locking Drill Guide 6–65 mm (80-0384) or 2.8 mm Hexalobe Locking Drill Guide 6–65 mm (80-0668) in the hole just proximal to the slotted hole in the shaft of the plate. Drill with the 2.8 mm Quick Release Drill (80-0387) and measure with the Depth Gauge 6–65 mm (80-0623) (Figure 9). Insert the proper-length 3.5 mm Locking Hex or Locking Hexalobe Screw (30-023X or COL-3XXX) using the 2.5 mm Quick Release Hex Driver (HPC-0025) or the T15 Stick Fit Hexalobe Driver (80-0760), the 3.5 mm Screw Driver Sleeve (MS-SS35), and the Medium Ratcheting Driver Handle (80-0663) (Figure 10), taking care that the screw does not exit the bone dorsally.

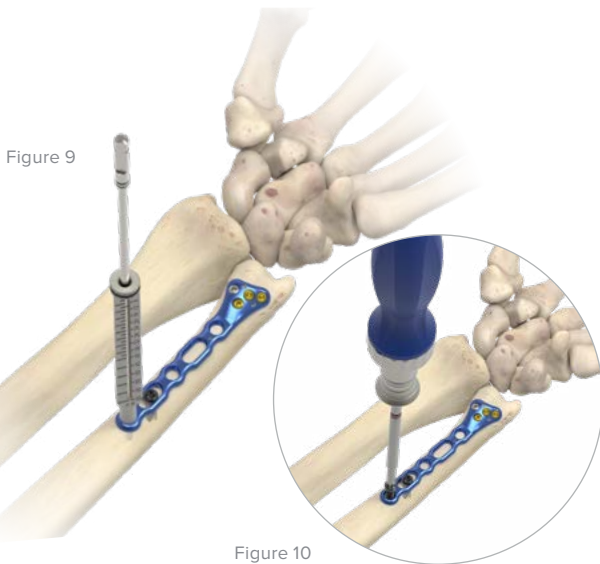

Figure 9

Figure 10

Using the same process, drill and place the final locking screw in the remaining locking hole. Remove the proximal K-wire.

**Note:** 3.5 mm locking or nonlocking hex or hexalobe screws can be used in the proximal round locking holes.

**Optional:** A 2.7 mm Locking Low-Profile Hexalobe Screw (3040-230XX) can be used in place of the 3.5 mm screw using the 2.0 mm Quick Release Drill (80-0318) and the 2.0 mm Hexalobe Locking Drill Guide (80-4029).

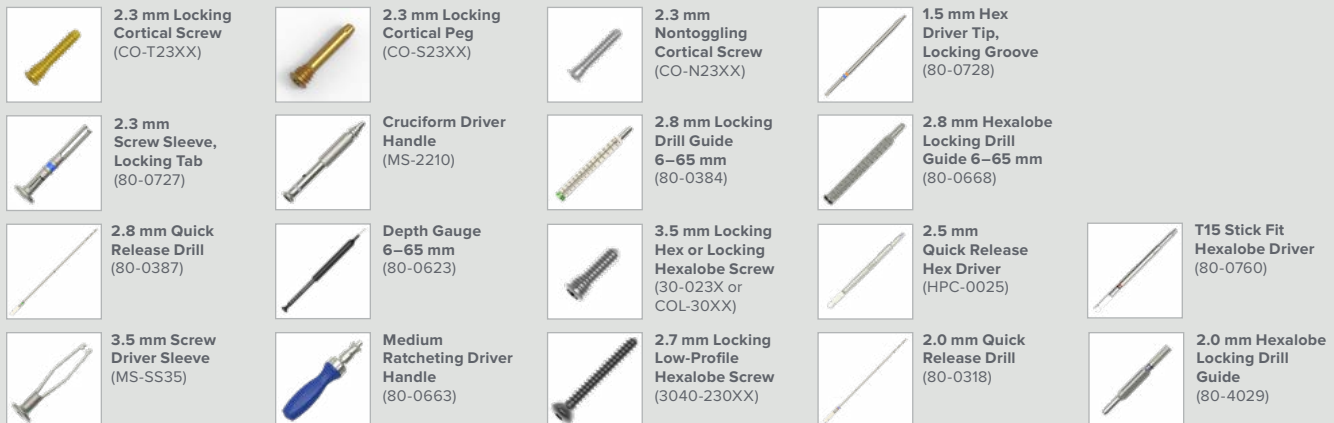

# Acu-Loc Volar Distal Ulna (VDU) Plate Surgical Technique [continued]

## 7 Closure and Postoperative Protocol

Following thorough radiographic evaluation, check alignment and rotation, then close (Figure 11). Start immediate finger range of motion and forearm rotation postoperatively. Allow early functional use of the hand for light activities of daily living (ADL). Support the wrist according to bone quality and stability.

Closing and postoperative protocol are at the discretion of the surgeon.



Figure 11

## 8 Optional: Implant Removal Instructions

To extract an Acu-Loc Volar Distal Ulna Plate, use the 2.5 mm Hex Driver (HPC-0025) or T15 Stick Fit Hexalobe Driver (80-0760) and Medium Ratcheting Driver Handle (80-0663) to remove all the 3.5 mm screws in the plate. Use the T8 Stick Fit Hexalobe Driver (80-0759) and Medium Ratcheting Driver Handle (80-0663) to remove any 2.7 mm screws. Use the 1.5 mm Hex Driver Tip, Locking Groove (80-0728) with the Cruciform Driver Handle (MS-2210) for the 2.3 mm screws.

Referencing the Screw Removal Brochure (SPF10-00) may aid in implant extraction if difficulty is experienced.



2.5 mm Hex Driver  
(HPC-0025)



T15 Stick Fit  
Hexalobe  
Driver  
(80-0760)



Medium  
Ratcheting Driver  
Handle  
(80-0663)



T8 Stick Fit  
Hexalobe Driver  
(80-0759)



1.5 mm Hex Driver  
Tip, Locking  
Groove  
(80-0728)



Cruciform Driver  
Handle  
(MS-2210)

# Acu-Loc Dorsal Plate Surgical Technique

William B. Geissler, MD

## Acu-Loc Dorsal Plate Reference Chart

<b>Blue</b>	Left-specific
<b>Green</b>	Right-specific



Figure 1

## 1 Incision and Dissection

Make the dorsal approach incision in line with Lister's tubercle and the radial border of the long finger (Figure 1). Carry down blunt dissection to protect the dorsal cutaneous nerve branches. Distally identify the extensor pollicis longus tendon in the wound and release through the third dorsal compartment. Then subperiosteally elevate the second and fourth compartments. Use caution when elevating the second and fourth dorsal compartments as bone fragments may have adhered to their undersurface.

A neurectomy of the posterior interosseous nerve may then be performed at the surgeon's discretion. Identify the posterior interosseous nerve on the radial aspect of the fourth compartment as it is elevated. A neurectomy is recommended on the proximal aspect of the incision to decrease neuroma pain.

## 2 Plate Placement and Provisional Fixation

Anatomically reduce the fracture with traction and volar translation. The Acu-Loc Dorsal Plate (70-005X) can be used as a buttress to help push and volarly reduce the dorsal displaced fracture fragments. The reduction of the fracture and correct plate position are verified under fluoroscopy and the plate is provisionally stabilized with K-wires. Place the proximal shaft of the plate just radial to the most convex position of the radial shaft. The appropriate right or left Acu-Loc 2 Dorsal Targeting Guide (80-015X) may be attached to the appropriate plate using the Acu-Loc Radiolucent Targeting Guide (80-0038) on the back table prior to insertion and then placed on the bone (Figure 2).

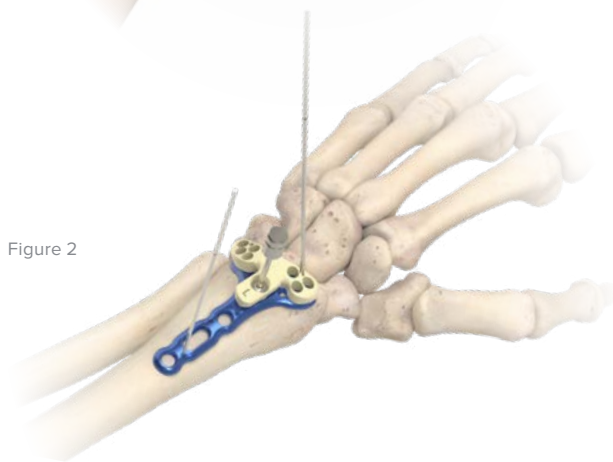

Figure 2



Acu-Loc Dorsal Plate (70-005X)



Acu-Loc 2 Dorsal Targeting Guide (80-015X)



Locking Screw, Acu-Loc Radiolucent Targeting Guide (80-0038)

## Acu-Loc Dorsal Plate Surgical Technique [continued]

### 3 Nonlocking Proximal Screw Placement

Place the first 3.5 mm Nonlocking Hex or Hexalobe Screw (30-02XX or CO-31XX) in the center of the proximal slot in the plate. The position of the plate relative to the articular surface can then be fine-tuned by sliding the plate proximally or distally under fluoroscopy. Using the 2.8 mm Quick Release Drill (80-0387) and 2.0 mm / 2.8 mm Thin Drill Guide (PL-2118), drill through the far cortex (Figure 3). Measure drill depth with the Depth Gauge 6–65 mm (80-0623). Insert the appropriate 3.5 mm nonlocking hex or hexalobe screw, taking care that the screw is the proper length. The screw reduces the plate down to the bone and the length of the screw should be assessed under fluoroscopy following the insertion of the remaining screws. The screw may need to be downsized after the plate has been reduced down to the bone.

**Optional:** A 2.7 mm Nonlocking Low-Profile Hexalobe Screw (3041-230XX) can be used in place of the 3.5 mm screw using the 2.0 mm Quick Release Drill (80-0318).

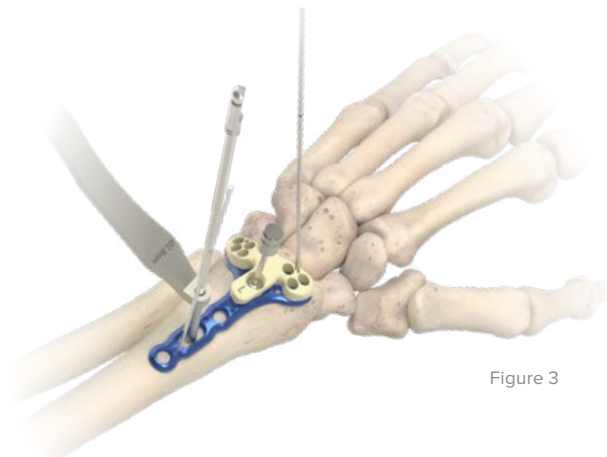

Figure 3

### 4 Drill Distal Screw Holes

To assess the position of the distal screws relative to the articular surface and the dorsum of the radius, a .054" x 6" K-wire (WS-1406ST) may be placed through the distal K-wire holes on the targeting guide and plate. The fracture reduction, plate position, and location of the K-wire relative to the joint are assessed under fluoroscopy. If the distal K-wires do not penetrate the joint, the distal 2.3 mm screws will not, either. Care should be taken not to angle the distal K-wires.

Select one of the four distal screw holes closest to the joint to drill first. Insert the Drill Guide / Depth Gauge for 2.0 mm Drill (MS-DG23) into the selected hole, followed by the 2.0 mm Quick Release Drill (80-0318) (Figure 4). Measure the depth of the screw using the laser mark on the drill shaft and scale on the drill guide. As an alternative, the Distal Radius Probe (MS-DRPB) may be used by hooking the far cortex and measuring with the laser mark on the probe.

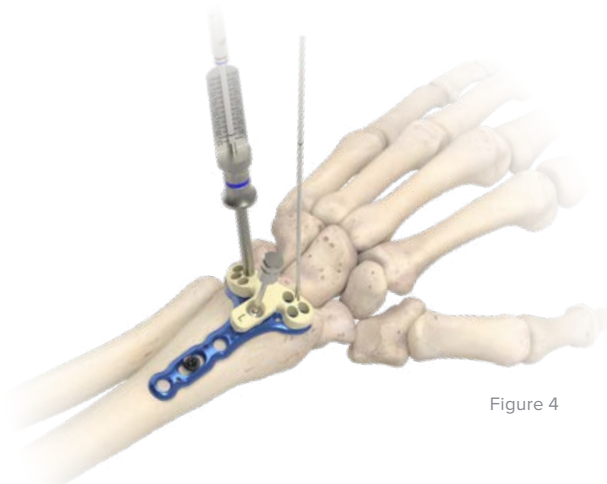
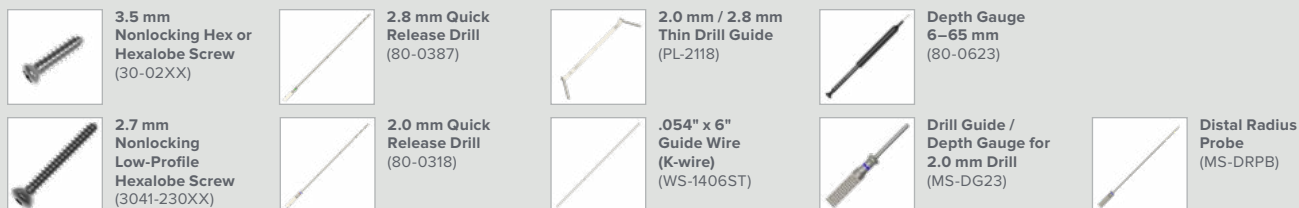

Figure 4



## Acu-Loc Dorsal Plate Surgical Technique [continued]

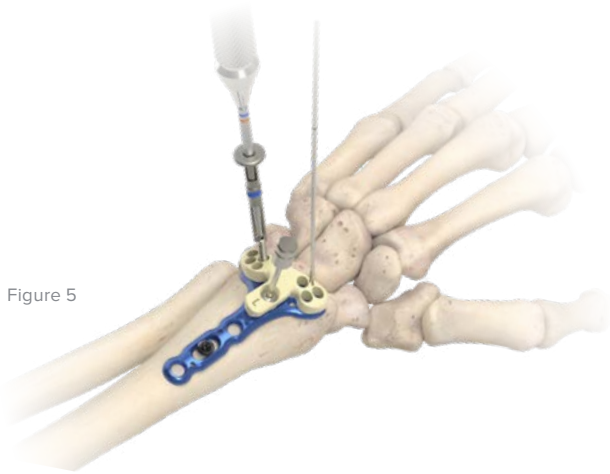

Figure 5

### 5 Distal Screw Placement

The three types of 2.3 mm screws that can be used in any of the eight distal holes are Locking Cortical Screws (gold) (CO-T23XX), Locking Cortical Pegs (bronze) (CO-S23XX), and Nontoggling Cortical Screws (silver) (CO-N23XX). Insert all 2.3 mm screws using the 1.5 mm Hex Driver Tip, Locking Groove (80-0728), 2.3 mm Screw Sleeve, Locking Tab (80-0727), and the silver Cruciform Driver Handle (MS-2210) (Figures 5 and 6).

**Note:** A 2.0 mm Locking Drill Guide 4–32 mm (80-0249) is available in the system as an alternative for drilling the distal holes. Screw length can be read using the Distal Radius Probe (MS-DRPB) or 2.3 mm Screw Depth Gauge 6–46 mm (80-1356).





## Acu-Loc Dorsal Plate Surgical Technique [continued]

### 6 Proximal Screw Placement

In the second proximal locking hole, thread in the 2.8 mm Locking Drill Guide (80-0384) or the 2.8 mm Hexalobe Locking Drill Guide (80-0668). Drill using the 2.8 mm Quick Release Drill (80-0387) and measure with the Depth Gauge 6–65 mm (80-0623) (Figure 7). Insert the proper-length 3.5 mm Locking Hex or Locking Hexalobe Screw (30-023X or COL-3XXX) using the 2.5 mm Quick Release Hex Driver (HPC-0025) or the T15 Stick Fit Hexalobe Driver (80-0760), the 3.5 mm Screw Driver Sleeve (MS-SS35), and the Medium Ratcheting Driver Handle (80-0663) (Figure 8). Place the final locking screw using the same process.

**Note:** 3.5 mm locking or nonlocking hex or hexalobe screws can be used in the proximal round locking holes.

**Optional:** A 2.7 mm Locking Low-Profile Hexalobe Screw (3040-230XX) can be used in place of the 3.5 mm screw using the 2.0 mm Quick Release Drill (80-0318) and the 2.0 mm Hexalobe Locking Drill Guide (80-4029).

### 7 Closure and Postoperative Protocol

Following thorough radiographic evaluation, the wound is closed in layers (Figure 9). The retinacula of the second and fourth dorsal compartments are repaired. The retinaculum for the third dorsal compartment may be repaired, or the extensor pollicis longus tendon may be left out of its compartment depending on the surgeon's discretion. Immediate finger range of motion is initiated postoperatively. Forearm rotation and wrist range of motion are progressed at the surgeon's discretion according to the bone quality, fracture stability, and associated soft-tissue injuries.

Closing and postoperative protocol are at the discretion of the surgeon.



Figure 6

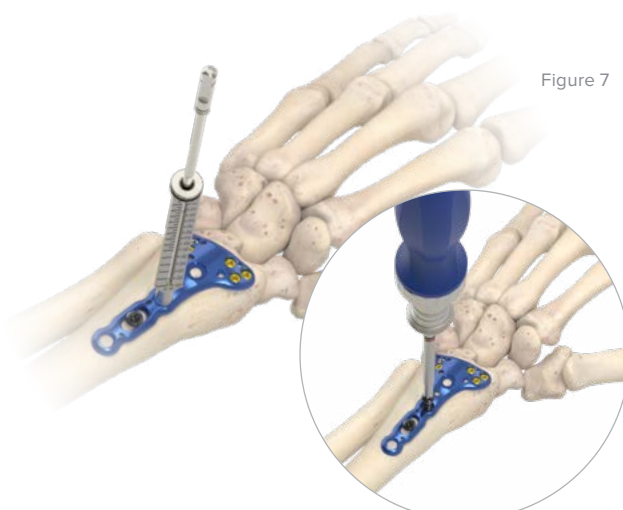

Figure 7

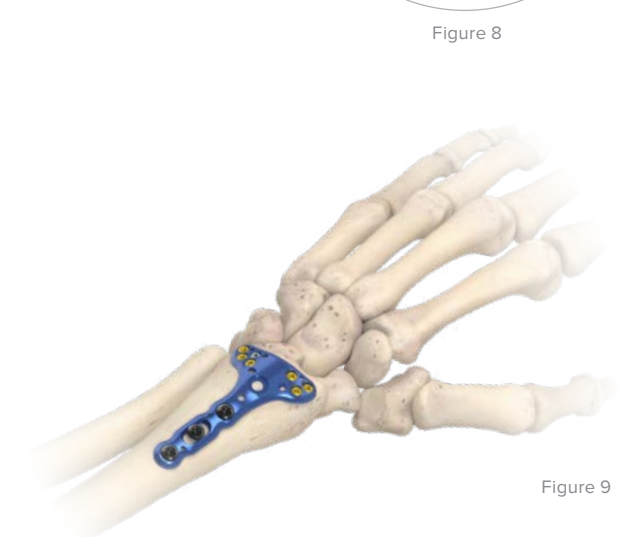

Figure 8



Figure 9



2.8 mm Locking Drill Guide or Hexalobe Locking Drill Guide (80-0384 or 80-0668)



2.8 mm Quick Release Drill (80-0387)



Depth Gauge 6–65 mm (80-0623)



3.5 mm Locking Hex or Locking Hexalobe Screw (30-023X or COL-3XXX)



2.5 mm Quick Release Hex Driver (HPC-0025)



2.7 mm Locking Low-Profile Hexalobe Screw (3040-230XX)



2.0 mm Quick Release Drill (80-0318)



2.0 mm Hexalobe Locking Drill Guide (80-4029)

## Acu-Loc Dorsal Plate Surgical Technique [continued]

### 8 Optional: Implant Removal Instructions

To extract an Acu-Loc Dorsal Plate, use the 2.5 mm Quick Release Hex Driver (HPC-0025) or T15 Stick Fit Hexalobe Driver (80-0760) and Medium Ratcheting Driver Handle (80-0663) to remove all the 3.5 mm screws in the plate. Use the T8 Stick Fit Hexalobe Driver (80-0759) and Medium Ratcheting Driver Handle (80-0663) to remove any 2.7 mm screws. Use the 1.5 mm Hex Driver Tip, Locking Groove (80-0728) with Cruciform Driver Handle (MS-2210) for the 2.3 mm screws.

Referencing the Screw Removal Brochure (SPF10-00) may aid in implant extraction if difficulty is experienced.



T15 Stick Fit Hexalobe Driver (80-0760)



3.5 mm Screw Driver Sleeve (MS-SS35)



Medium Ratcheting Driver Handle (80-0663)



T8 Stick Fit Hexalobe Driver (80-0759)



1.5 mm Hex Driver Tip, Locking Groove (80-0728)



Cruciform Driver Handle (MS-2210)

# Acu-Loc Extra-Articular (EX) Plate Surgical Technique

William B. Geissler, MD

## 1 Incision and Dissection

Supinate the patient's forearm to expose the surgical site. To maximize exposure, place a towel under the wrist, placing it in extension. Make a longitudinal incision approximately 6 cm in length just radial to the flexor carpi radialis (FCR) tendon to protect against potential injury to the palmar cutaneous branch of the median nerve (Figure 1).

Open the tendon sheath and radially retract the tendon to protect the radial artery. Identify the flexor pollicis longus by passive flexion / extension of the thumb interphalangeal joint and retract ulnarly to protect the median nerve. Next identify the pronator quadratus by its transverse fibers and release radial to the ulnar to expose the fracture site.



Figure 1

## 2 Provisional Fixation and Plate Placement

Reduce the fracture and evaluate under fluoroscopy. The brachioradialis may need to be released from its insertion on the radial styloid to facilitate reduction and visualization.

Make the Acu-Loc EX Standard or Narrow Plate (70-006X) sit along the flat metaphyseal portion of the distal radius (Figure 2). The appropriate Acu-Loc EX Targeting Guide (80-0166 or 80-0274) may be attached to the selected plate using the Locking Screw, Acu-Loc Radiolucent Targeting Guide (80-0038). This may be done on the back table prior to insertion. Secure the plate's position proximally and distally with a .054" x 6" K-wire (WS-1406ST). If the guide is not already attached to the plate, slide the guide over the distal K-wire and into position (Figure 3).

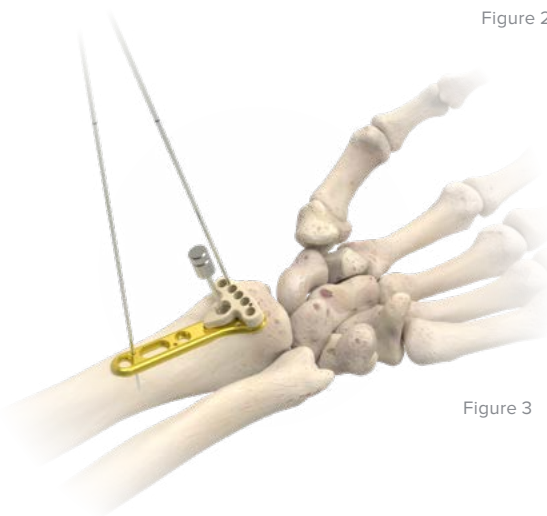

Figure 2

Figure 3



Acu-Loc EX Standard or Narrow Plate (70-006X)



Locking Screw, Acu-Loc Radiolucent Targeting Guide (80-0038)



.054" x 6" Guide Wire (K-wire) (WS-1406ST)



Acu-Loc EX Targeting Guide, Standard (80-0166)



Acu-Loc EX Targeting Guide, Narrow (80-0274)

# Acu-Loc Extra-Articular (EX) Plate Surgical Technique [continued]

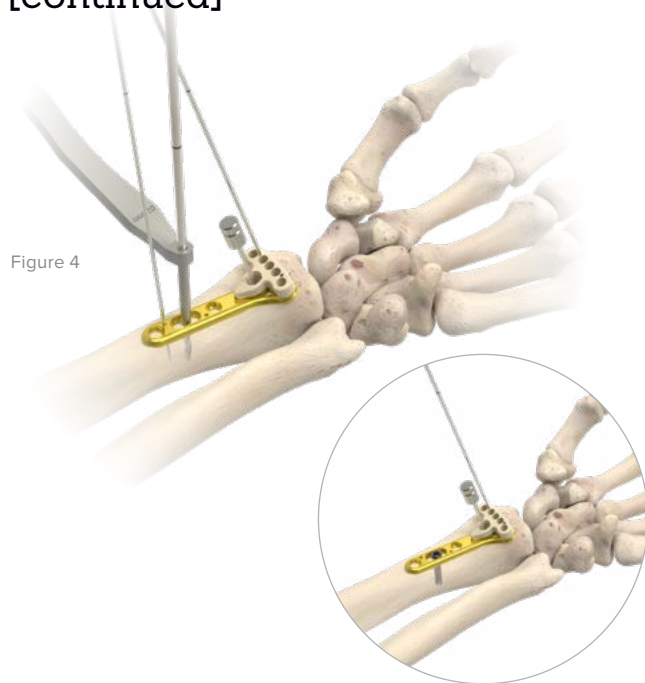

Figure 4

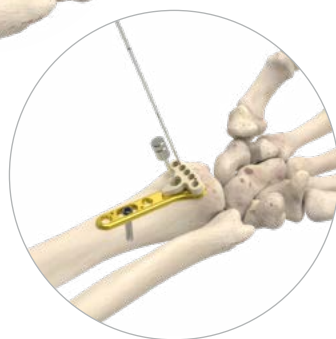

Figure 5

## 3 Nonlocking Proximal Screw Placement

Place the first 3.5 mm Nonlocking Hex or Hexalobe Screw (30-02XX) in the center of the proximal slot in the plate.

The position of the plate relative to the articular surface can then be fine-tuned by sliding the plate proximally or distally under fluoroscopy. Using the 2.8 mm Quick Release Drill (80-0387) and the 2.0 mm / 2.8 mm Thin Drill Guide (PL-2118), drill through the far cortex (Figure 4). Measure drill depth with the Depth Gauge 6–65 mm (80-0623). Insert the appropriate 3.5 mm nonlocking hex or hexalobe screw, taking care that the screw is the proper length. The screw reduces the plate down to the bone and the length of the screw should be assessed under fluoroscopy following the insertion of the remaining screws. The screw may need to be downsized after the plate has been reduced down to the bone.

**Optional:** A 2.7 mm Nonlocking Low-Profile Hexalobe Screw (3041-230XX) can be used in place of the 3.5 mm screw using the 2.0 mm Quick Release Drill (80-0318).

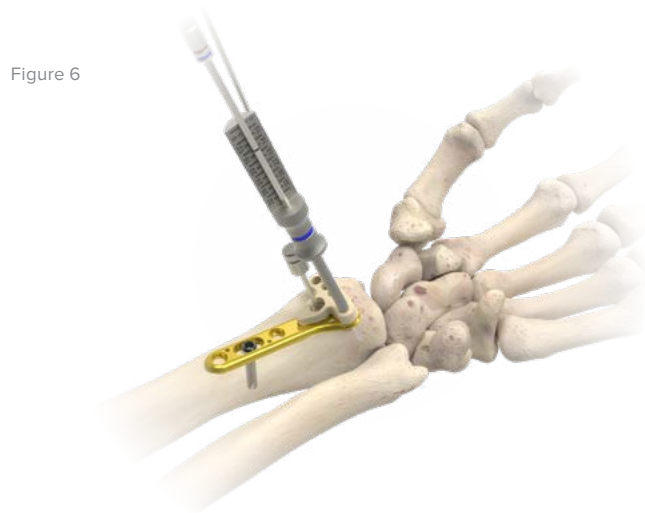

Figure 6

## 4 Drill Distal Screw Holes

To assess the position of the distal locking screws relative to the articular surface and the dorsum of the radius, a .054" x 6" K-wire (WS-1406ST) may be placed through the distal K-wire holes on the targeting guide and plate (Figure 5). Under fluoroscopy, assess the fracture reduction, the plate position, and the location of the K-wire relative to the joint.

If the distal K-wires do not penetrate the joint, the distal 2.3 mm screws will not either. Insert the Drill Guide / Depth Gauge for 2.0 mm Drill (MS-DG23) into one of the five distal holes, followed by the 2.0 mm Quick Release Drill (80-0318) (Figure 6). The depth of the screw is measured using the laser mark on the drill shaft and scale on the drill guide. As an alternative, the Distal Radius Probe (MS-DRPB) may be used by hooking the far cortex and measuring with the laser mark on the probe.

**Note:** Refer to the 2.3 mm Locking Variable Angle Screw Reference Information on page 8 and the Surgical Technique on page 45.



# Acu-Loc Extra-Articular (EX) Plate Surgical Technique [continued]

## 5 Distal Screw Placement

The three types of 2.3 mm screws that can be used in any of the five distal holes are Locking Cortical Screws (gold) (CO-T23XX), Locking Cortical Pegs (bronze) (CO-S23XX), and Nontoggling Cortical Screws (silver) (CO-N23XX). Insert all 2.3 mm screws using the 1.5 mm Hex Driver Tip, Locking Groove (80-0728), the 2.3 mm Screw Sleeve, Locking Tab (80-0727), and the silver Cruciform Driver Handle (MS-2210) (Figures 7 and 8).

**Variable Angle Screw:** 2.3 mm Locking Variable Angle Screws (30-23XX) may be used with the Acu-Loc EX Plates. Refer to the 2.3 mm Locking Variable Angle Screw Reference Information on page 8 and the Surgical Technique on page 45.

**Note:** An individual 2.0 mm Locking Drill Guide 4–32 mm (80-0249) is available in the system as an alternative for drilling the distal holes. Screw length can be read using the Distal Radius Probe (MS-DRPB) or 2.3 mm Screw Depth Gauge, 6–46 mm (80-1356).

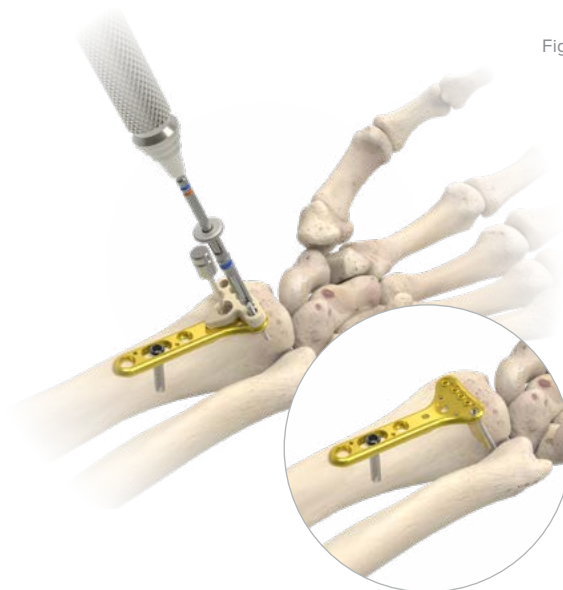

Figure 7



Figure 8





# Acu-Loc Extra-Articular (EX) Plate Surgical Technique [continued]

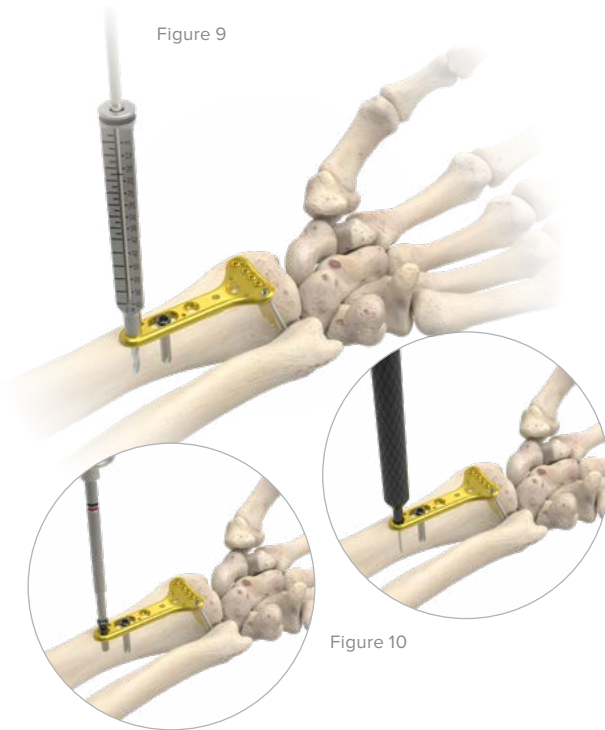

Figure 9

Figure 10

Figure 11

## 6 Proximal Screw Placement

Select one of the two remaining proximal holes and insert the threaded 2.8 mm Locking or Hexalobe Locking Drill Guide (80-0384 or 80-0668). Drill with the 2.8 mm Quick Release Drill (80-0387) and measure with the depth gauge. Insert the proper-length 3.5 mm Locking Hex or Locking Hexalobe Screw (30-023X or COL-3XXX) using the 2.5 mm Quick Release Hex Driver (HPC-0025) or the T15 Stick Fit Hexalobe Driver (80-0760), the 3.5 mm Screw Driver Sleeve (MS-SS35), and the Medium Ratcheting Driver Handle (80-0663).

Using the same process, drill and place the final locking screw (Figures 9–11).

**Note:** 3.5 mm locking or nonlocking hex or hexalobe screws can be used in the proximal round locking holes.

**Optional:** A 2.7 mm Locking Low-Profile Hexalobe Screw (3040-230XX) can be used in place of the 3.5 mm screw using the 2.0 mm Quick Release Drill (80-0318) and the 2.0 mm Hexalobe Locking Drill Guide (80-4029).

**Caution:** Take care to ensure that the screw does not exit the bone dorsally.



Figure 12

## 7 Closure and Postoperative Protocol

Following thorough radiographic evaluation, check alignment and rotation, then close (Figure 12). Start immediate finger range of motion and forearm rotation postoperatively. Allow early functional use of the hand for light activities of daily living (ADL). Support the wrist according to bone quality and stability.

Closing and postoperative protocol are at the discretion of the surgeon.



2.8 mm Locking Drill Guide (80-0384 or 80-0668)



2.8 mm Quick Release Drill (80-0387)



3.5 mm Locking Hex or Locking Hexalobe Screw (30-023X or COL-3XXX)



2.5 mm Quick Release Hex Driver (HPC-0025)



T15 Stick Fit Hexalobe Driver (80-0760)



3.5 mm Screw Driver Sleeve (MS-SS35)



Medium Ratcheting Driver Handle (80-0663)



2.7 mm Locking Low-Profile Hexalobe Screw (3040-230XX)



2.0 mm Quick Release Drill (80-0318)



2.0 mm Hexalobe Locking Drill Guide (80-4029)



# Acu-Loc Extra-Articular (EX) Plate Surgical Technique [continued]

## 8 Optional: Implant Removal Instructions

To extract an Acu-Loc EX Plate, use the 2.5 mm Hex Driver Tip (HPC-0025) or T15 Stick Fit Hexalobe Driver (80-0760) and Medium Ratcheting Driver Handle (80-0663) to remove all the 3.5 mm screws in the plate. Use the T8 Stick Fit Hexalobe Driver (80-0759) and Medium Ratcheting Driver Handle (80-0663) to remove any 2.7 mm screws. Use the 1.5 mm Hex Driver Tip, Locking Groove (80-0728) with Cruciform Driver Handle (MS-2210) for the 2.3 mm screws.

Referencing the Screw Removal Brochure (SPF10-00) may aid in implant extraction if difficulty is experienced.



2.5 mm Hex  
Driver Tip  
(HPC-0025)



T15 Stick Fit  
Hexalobe Driver  
(80-0760)



Medium  
Ratcheting Driver  
Handle  
(80-0663)



T8 Stick Fit  
Hexalobe Driver  
(80-0759)



1.5 mm Hex Driver  
Tip, Locking  
Groove  
(80-0728)



Cruciform Driver  
Handle  
(MS-2210)

# Frag-Loc® Compression Screw Surgical Technique

Figure 1



Figure 2



## 1 Drilling Bicortically

With the targeting guide attached, drill bicortically, using the 2.0 mm Quick Release Drill (80-0318) through the 2.0 mm Locking Drill Guide 4–32 mm (80-0249) or the Drill Guide / Depth Gauge for 2.0 mm Drill (MS-DG23) (Figures 1 and 2).

## 2 Measuring to Determine Screw Type

Measure screw length using the Distal Radius Probe (MS-DRPB) (Figure 3).

### Probe Guidelines:

**16–24 mm** acceptable to use with the Frag-Loc Compression Sleeve (30-0370) and the Frag-Loc Compression Screw (30-0371).

**20–28 mm** acceptable to use with the Frag-Loc Compression Sleeve (30-0370) and the Frag-Loc Compression Screw, Long (30-0372).

### Caution:

- ▶ Do not use the Frag-Loc Compression Screw outside of 16–24 mm range.
- ▶ Do not use the Frag-Loc Compression Screw, Long outside of 20–28 mm range.

Figure 3

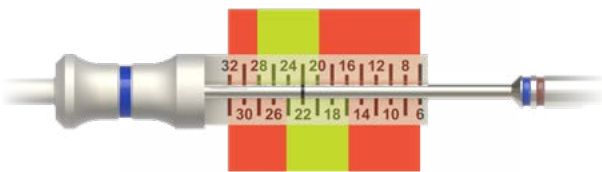

Figure 4



## 3 Drilling Unicortically

Drill using the Frag-Loc 2.5 mm Drill (80-0724) and Frag-Loc 2.5 mm Drill Guide (80-0730) (Figure 4). The shoulder of the drill must stop against the top of the drill guide.



2.0 mm Quick Release Drill (80-0318)



2.0 mm Locking Drill Guide 4–32 mm (80-0249)



Drill Guide / Depth Gauge for 2.0 mm Drill (MS-DG23)



Distal Radius Probe (MS-DRPB)



Frag-Loc Compression Sleeve (30-0370)



Frag-Loc Compression Screw (30-0371)



Frag-Loc Compression Screw, Long (30-0372)



Frag-Loc 2.5 mm Drill (80-0724)



Frag-Loc 2.5 mm Drill Guide (80-0730)

# Frag-Loc® Compression Screw Surgical Technique [continued]

## 4 Frag-Loc Sleeve Insertion

Insert the Frag-Loc Compression Sleeve (30-0370) into the plate using the silver Cruciform Driver Handle (MS-2210) with the 1.5 mm Hex Driver Tip, Locking Groove (80-0728) (Figures 5 and 6).

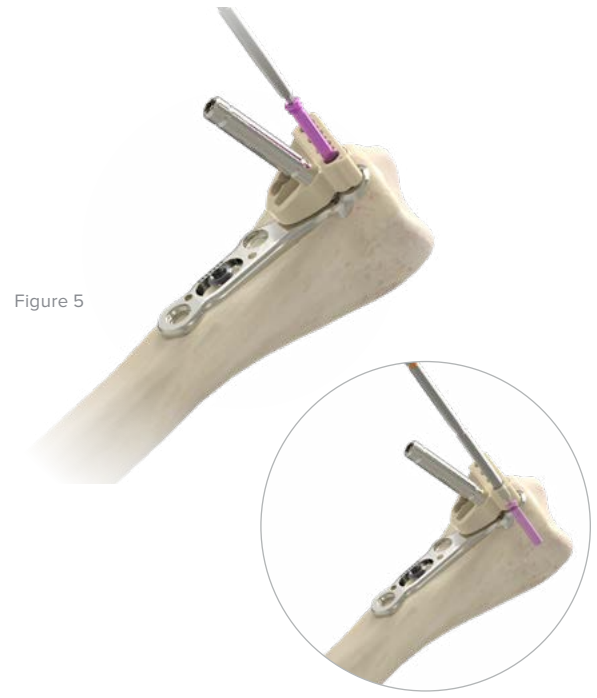

Figure 5

Figure 6

## 5 K-wire Insertion

Insert the .035" x 5.75" K-wire (WS-0906ST) through the Frag-Loc Compression Sleeve and dorsal skin (Figure 7).



Figure 7



Frag-Loc Compression Sleeve (30-0370)



Cruciform Driver Handle (MS-2210)



1.5 mm Hex Driver Tip, Locking Groove (80-0728)



.035" x 5.75" Guide Wire (K-wire) (WS-0906ST)

# Frag-Loc® Compression Screw Surgical Technique [continued]

Figure 8

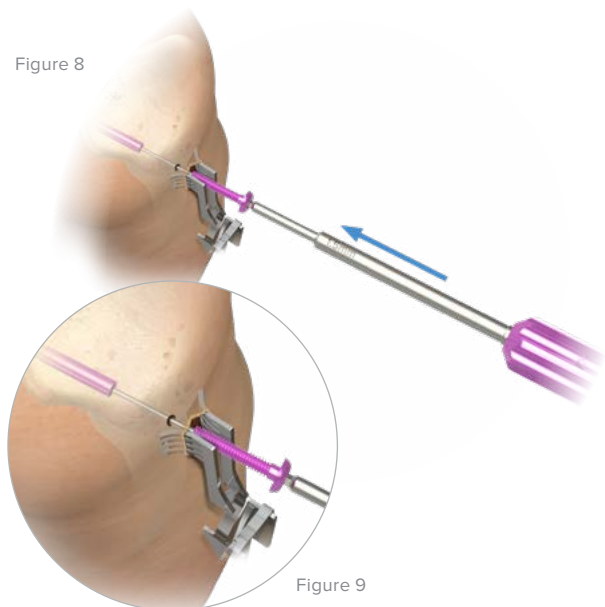

Figure 9

## 6 Frag-Loc Wire Insertion

Make a small incision dorsally over the K-wire and use the Heiss Retractor (80-0756) to maintain clearance of soft-tissue and tendons.

Drive the Frag-Loc Compression Screw (30-0371) or the Frag-Loc Compression Screw, Long (30-0372) over the .035" x 5.75" K-wire (WS-0906ST) using the Frag-Loc 1.5 mm Cannulated Driver (80-0758) (Figure 8).

Tighten the Frag-Loc Compression Screw into the Frag-Loc Compression Sleeve (30-0370) until the desired compression is achieved (Figure 9).

Ensure the Frag-Loc Compression Screw head is fully seated on the bone and that the tendons are clear of the screw head.

## 7 Final Confirmation

Remove the targeting guide.

Check Frag-Loc thread engagement using the Frag-Loc Depth Gauge (80-0726). The depth gauge ensures that the minimum number of threads are engaged into the Frag-Loc Compression Sleeve (30-0370) (Figure 10).

**Note:** A visible laser band on the depth gauge ensures acceptable Frag-Loc thread engagement (Figure 11).

If the depth gauge laser band is not visible, tighten the Frag-Loc Compression Screw one revolution and recheck (Figure 12). Repeat until the laser band is visible.

Figure 10

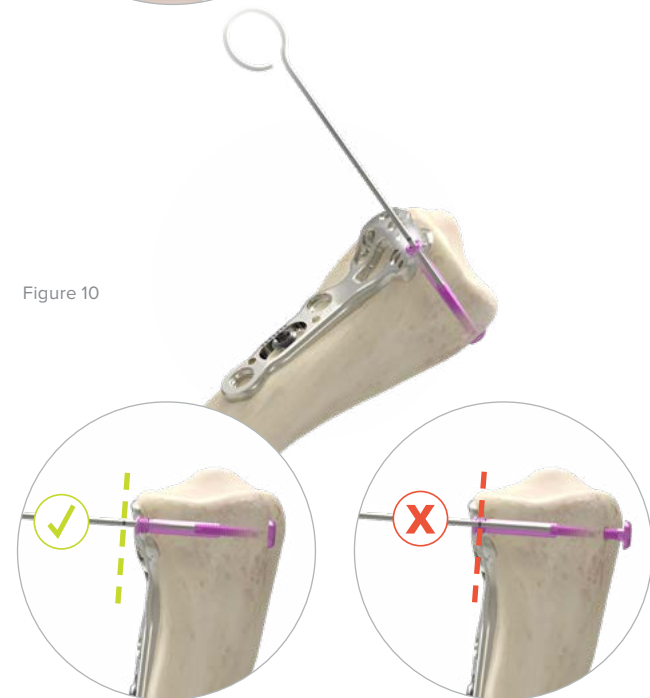

Figure 11

Figure 12

## 8 Optional: Implant Removal Instructions

To extract the Frag-Loc Compression Screw, use the 1.5 mm Hex Driver Tip, Locking Groove (80-0728) with the Cruciform Driver Handle (MS-2210).

Referencing the Screw Removal Brochure (SPF10-00) may aid in implant extraction if difficulty is experienced.



Heiss Retractor (80-0756)



Frag-Loc Compression Screw (30-037X)



.035" x 5.75" Guide Wire (K-wire) (WS-0906ST)



Frag-Loc 1.5 mm Cannulated Driver (80-0758)



Frag-Loc Compression Sleeve (30-0370)



Frag-Loc Depth Gauge (80-0726)



1.5 mm Hex Driver Tip, Locking Groove (80-0728)



Cruciform Driver Handle (MS-2210)

## 2.3 mm Locking Variable Angle Screw Surgical Technique

### 1 Conical Drill Guide Placement

If it is determined that a 2.3 mm Locking Variable Angle Screw (30-23XX) is needed, remove the radiolucent targeting guide from the plate and insert the conical 2.3 mm Variable Angle Drill Guide (80-0762), utilizing the 2.3 mm Variable Angle Drill Guide Driver (80-0763) (Figure 1).

Disconnect the drill guide driver once the drill guide is fully engaged into the plate (Figure 2).

**Note:** The drill guide driver allows for ease of insertion of the conical drill guide. It is not needed to remove the conical drill guide.

The Acumed 2.3 mm locking variable angle screws can be used in any distal hole of any of the gold-colored Acu-Loc 2 VDR Proximal Plates (70-0XXX) and Acu-Loc EX Plates (70-006X). The Acumed 2.3 mm locking variable angle screws can also be used in the silver-colored Acu-Loc 2 VDR Plates, but only in the distal styloid hole.

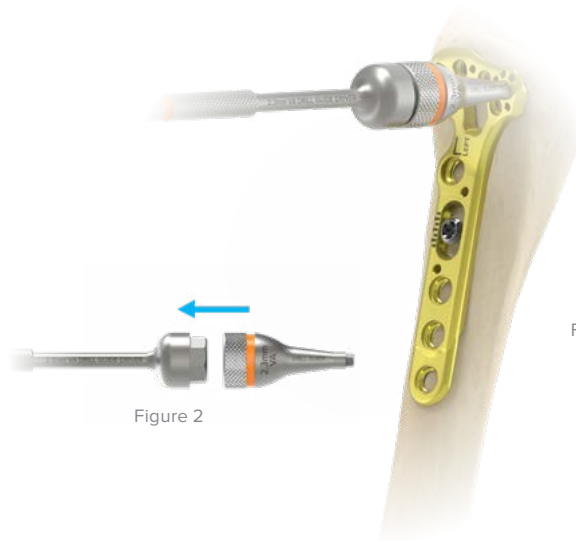

Figure 1



Figure 2

### 2 Drilling Distal Screws

Drill using the orange-banded 1.7 mm Quick Coupler Semi-Fluted Drill (80-0868) in the desired trajectory within the conical drill guide. Remove the conical drill guide (Figure 3 and 4).

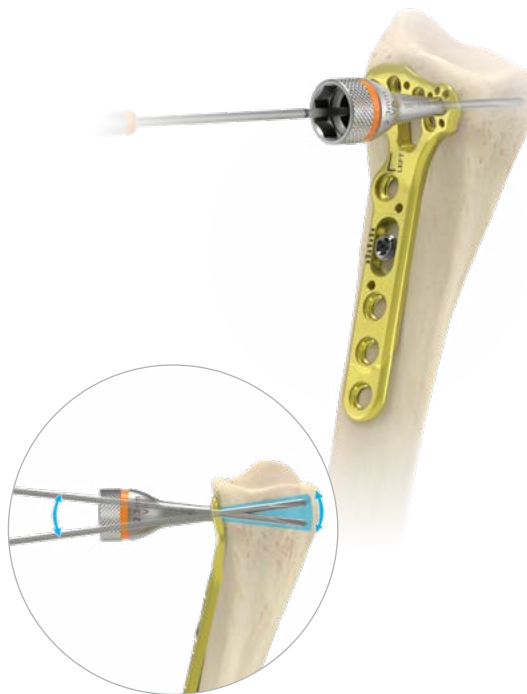

Figure 3

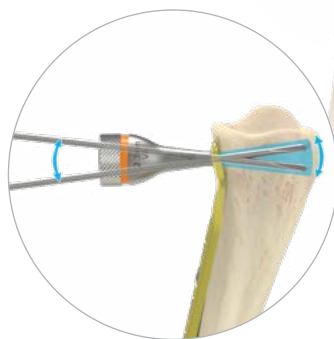

Figure 4



2.3 mm Locking Variable Angle Screw (30-23XX)



2.3 mm Variable Angle Drill Guide (80-0762)



2.3 mm Variable Angle Drill Guide Driver (80-0763)



Acu-Loc 2 VDR Proximal Plates (70-0XXX)



Acu-Loc EX Plates (70-006X)



1.7 mm Quick Coupler Semi-Fluted Drill (80-0868)

## 2.3 mm Locking Variable Angle Screw Surgical Technique [continued]

Figure 5



### 3 Measuring Distal Screws

Determine the screw length with the 2.3 mm Screw Depth Gauge 6–46 mm (80-1356) (Figure 5).

Figure 6



### 4 Distal Screw Insertion

Select and insert the corresponding 2.3 mm Locking Variable Angle Screw (30-23XX) using the 1.5 mm Hex Driver Tip, Locking Groove (80-0728), and the orange Mini-AO Torque Limiting Driver, 10 in-lb (80-1008) (Figure 6). Insert the screw until the torque limiting driver clicks once, indicating that the optimum insertion torque has been achieved.

**Caution:** Once the locking variable angle screw is fully inserted, inspect for and clear any debris from the perimeter of the screw head.

**Caution:** Locking variable angle screws are **one-time use only**.

Once the screw is engaged into the plate, it cannot be removed and reinserted into its original hole or any other hole of the Acu-Loc 2 VDR Proximal Plate or Acu-Loc EX Plate. If this screw is removed, it must be discarded to prevent reuse. A 2.3 mm Nontoggling Cortical Screw (CO-N23XX) must be used to replace a locking variable angle screw.

**Caution:** The Torque Limiting Driver must only be used in the clockwise direction. Do not use counter-clockwise, as this may inadvertently disassemble the driver. Replace the TLD after six months of normal use.

#### **Caution: Torque Limiting Driver (TLD) usage information**

There are two models of TLD (80-1008). The first generation may not maintain calibration past six months of normal use. Using the TLD when not calibrated may cause the screw to not seat fully (when inserted within the conical drill guide boundaries) or cause the threads to strip or the driver tip to break. Replace the first generation TLD after six months of normal use. See page 51 for additional details.



2.3 mm Screw Depth Gauge 6–46 mm (80-1356)



2.3 mm Locking Variable Angle Screw (30-23XX)



1.5 mm Hex Driver Tip, Locking Groove (80-0728)



Mini-AO Torque Limiting Driver, 10 in-lb (80-1008)



2.3 mm Nontoggling Cortical Screw (CO-N23XX)



## 2.3 mm Locking Variable Angle Screw Surgical Technique [continued]

Additionally, please note difference in handle shape in order to distinguish the two Mini-AO Torque Limiting Drivers. The images in this document demonstrate the differences between the existing Driver and the updated Driver.

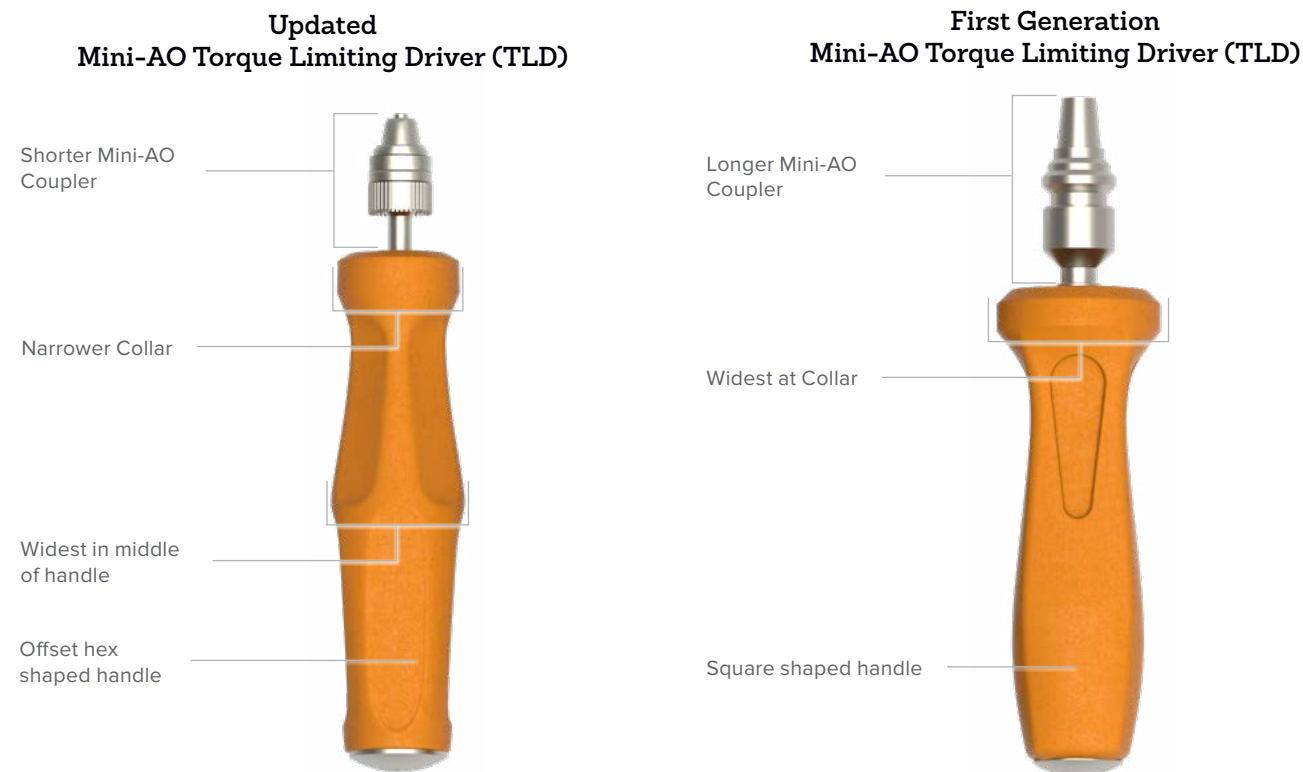

Figure 7

### 5 Optional: Implant Removal Instructions

To extract the Variable Angle Screw, use the 1.5 mm Hex Driver Tip, Locking Groove (80-0728) with the Cruciform Driver Handle (MS-2210) (Figure 7).

Referencing the Screw Removal Brochure (SPF10-00) may aid in implant extraction if difficulty is experienced.



1.5 mm Hex Driver Tip, Locking Groove (80-0728)



Cruciform Driver Handle (MS-2210)

## Volar Ulnar Corner Fixation

Figure 1



Figure 2



### Fixating Small Volar Ulnar Corner Fragments

This technique uses the DRFS Volar Lunate Suture Plate (70-0334) (Figure 1) or Acu-Loc 2 VDR Plate (70-03XX) (Figure 2). The volar ulnar fragment is typically rotated with its capsular attachment and de-rotated under direct visualization. Multiple sutures are placed in the capsule, rotating the fragment back anatomically.

Once the fragment is de-rotated, the sutures are passed through the suture holes in the volar ulnar corner of the plate. A plate-specific nonlocking screw is placed through the oblong slot in the plate. The plate is positioned onto the distal radius, with the preferred placement confirmed using fluoroscopy. The sutures are tied, securing the volar ulnar fragment with the plate, and the remaining screws are placed.<sup>1,2</sup>



DRFS Volar Lunate Suture Plate (70-0334)



Acu-Loc 2 VDR Plate (70-03XX)

# Volar Ulnar Corner Fixation

## K-wire Technique for Fixing Small Volar Ulnar Corner Fragments

An alternative technique using the Acu-Loc 2 VDR Plate (70-03XX) is the insertion of K-wires for fragment-specific fixation of the lunate and scaphoid facets. Directly reduce the lunate and/or scaphoid facet fragments using the Sharp Hook (PL-CL06) or the Fragment Reduction Tool (80-0725) (Figure 1).

- ▶ Insert a K-wire of appropriate size from volar to dorsal into the fragment. Repeat this step as needed for additional fragment stability.
- ▶ Cut the K-wire down and bend proximally to contour to the volar aspect of the distal radius. Leave enough wire exposed so that the fragment is secure and able to be fully covered by the Acu-Loc 2 VDR Plate (Figures 2 and 3).
- ▶ Select the appropriate Acu-Loc 2 VDR Plate (70-03XX) that adequately covers the K-wires and addresses the remaining distal radius fracture (Figure 4).

Figure 1



Figure 2



Figure 3

Figure 4



Acu-Loc 2 VDR Plate  
(70-03XX)



Sharp Hook  
(PL-CL06)



Fragment Reduction Tool  
(80-0725)

# Ordering Information

## Tray Components

### Instrumentation

1	8" Bone Reduction Forceps	MS-1280	12	KickStand Post 25°	80-0722
2	Heiss Retractor	80-0756	13	KickStand Post 20°	80-0721
3	Bone Reduction Forceps 6 ¾"	80-0723	14	KickStand Post 15°	80-0720
4	15 mm Hohmann Retractor	MS-46827	15	KickStand Post 10°	80-0719
5	Periosteal Elevator 7.5" x 6 mm Straight Edge	80-0693	16	KickStand Post 5°	80-0718
6	Sharp Hook	PL-CL06	17	.054" x 6" Guide Wire (K-wire)	WS-1406ST
7	Fragment Reduction Tool	80-0725	18	Plate Tack	PL-PTACK
8	VDR Plate Positioning Handle Assembly	80-0729	19	2.0 mm / 2.8 mm Thin Drill Guide	PL-2118
9	1.5 mm Easyout, Quick Release	80-0598	20	Depth Gauge 6–65 mm	80-0623
10	2.5 mm Easyout, Quick Release	80-0600	21	Cruciform Driver Handle	MS-2210
11	KickStand Post 5–30°	80-0731	22	Medium Ratcheting Driver Handle	80-0663
			23	Hand & Wrist General Instrument Platter	80-0754

For information about the Acu-Loc® Wrist Spanning Plate, please contact your local authorized Acumed distributor, call 888.627.9957, or visit [acumed.net](http://acumed.net).

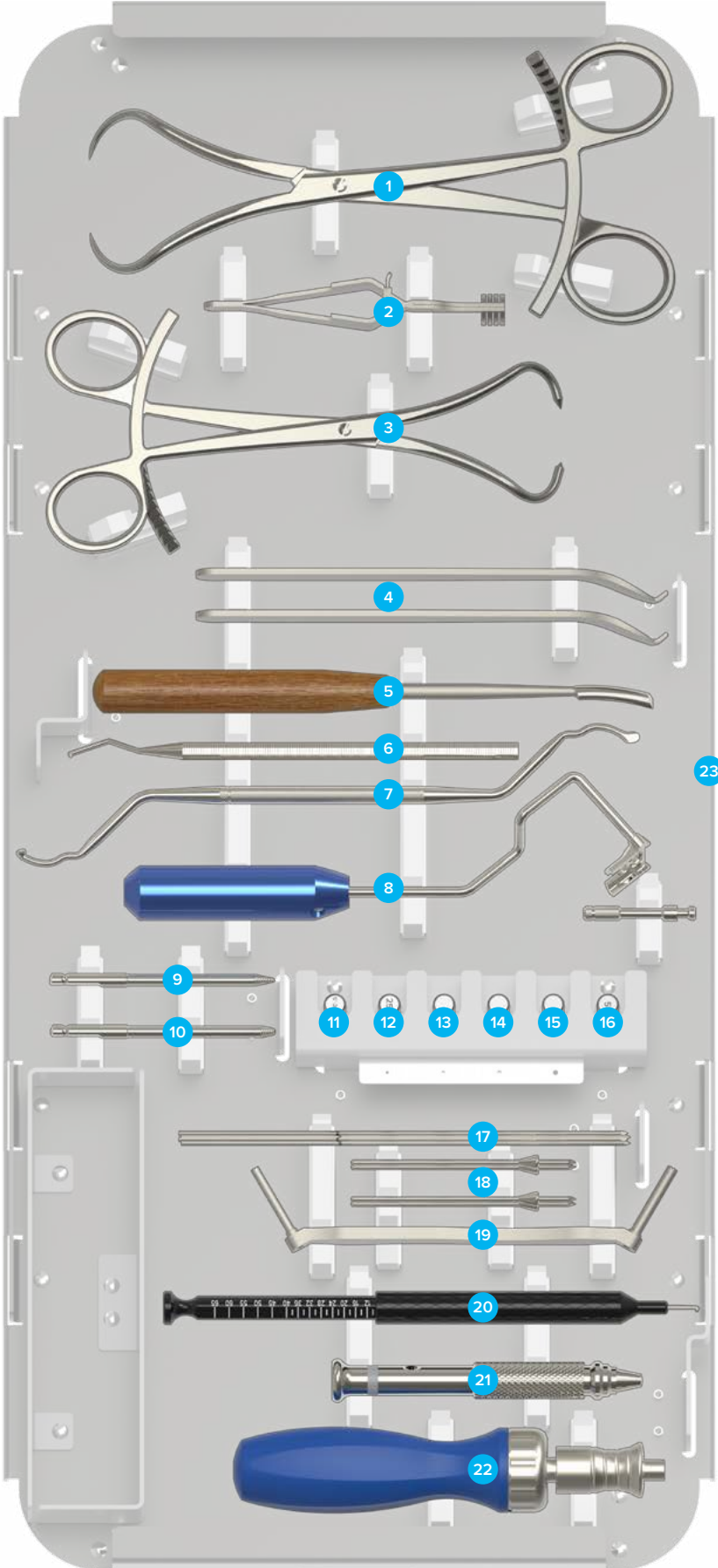

## Ordering Information [continued]

Tray Components					
<b>Acu-Loc 2 Volar Distal Radius (VDR) Plates</b>		<b>Instrumentation</b>			
1	Acu-Loc 2 VDR Plate Narrow, Left	70-0358	25	Acu-Loc 2 VDR Targeting Guide Locking Bolt	80-0682
2	Acu-Loc 2 VDR Plate Narrow Long, Left	70-0370	26	Acu-Loc 2 VDR Targeting Guide Narrow, Left	80-0697
3	Acu-Loc 2 VDR Plate Standard, Left	70-0356	27	Acu-Loc 2 VDR Targeting Guide Standard, Left	80-0695
4	Acu-Loc 2 VDR Plate Standard Long, Left	70-0368	28	Acu-Loc 2 VDR Targeting Guide Wide, Left	80-0699
5	Acu-Loc 2 VDR Plate Wide, Left	70-0360	29	Acu-Loc 2 VDR Targeting Guide Wide, Right	80-0698
6	Acu-Loc 2 VDR Plate Wide, Right	70-0361	30	Acu-Loc 2 VDR Targeting Guide Standard, Right	80-0694
7	Acu-Loc 2 VDR Plate Standard Long, Right	70-0369	31	Acu-Loc 2 VDR Targeting Guide Narrow, Right	80-0696
8	Acu-Loc 2 VDR Plate Standard, Right	70-0357	32	Acu-Loc 2 VDR Proximal Targeting Guide Narrow, Left	80-0703
9	Acu-Loc 2 VDR Plate Narrow Long, Right	70-0371	33	Acu-Loc 2 VDR Proximal Targeting Guide Standard, Left	80-0701
10	Acu-Loc 2 VDR Plate Narrow, Right	70-0359	34	Acu-Loc 2 VDR Proximal Targeting Guide Wide, Left	80-0705
<b>Acu-Loc 2 Volar Distal Radius (VDR) Proximal Plates</b>		35		Acu-Loc 2 VDR Proximal Targeting Guide Wide, Right	80-0704
11	Acu-Loc 2 VDR Proximal Plate Narrow, Left	70-0352	36	Acu-Loc 2 VDR Proximal Targeting Guide Standard, Right	80-0700
12	Acu-Loc 2 VDR Proximal Plate Narrow Long, Left	70-0382	37	Acu-Loc 2 VDR Proximal Targeting Guide Narrow, Right	80-0702
13	Acu-Loc 2 VDR Proximal Plate Standard, Left	70-0350	<b>Frag-Loc® Screws</b>		
14	Acu-Loc 2 VDR Proximal Plate Standard Long, Left	70-0372	38	Frag-Loc Compression Sleeve	30-0370
15	Acu-Loc 2 VDR Proximal Plate Wide, Left	70-0354	39	Frag-Loc Compression Screw, Long	30-0372
16	Acu-Loc 2 VDR Proximal Plate Wide, Right	70-0355	40	Frag-Loc Compression Screw	30-0371
17	Acu-Loc 2 VDR Proximal Plate Standard Long, Right	70-0373	<b>Frag-Loc® Instrumentation</b>		
18	Acu-Loc 2 VDR Proximal Plate Standard, Right	70-0351	41	Frag-Loc 2.5 mm Drill Guide	80-0730
19	Acu-Loc 2 VDR Proximal Plate Narrow Long, Right	70-0383	42	Frag-Loc 1.5 mm Cannulated Driver Assembly	80-0758
20	Acu-Loc 2 VDR Proximal Plate Narrow, Right	70-0353	43	.035" X 5.75" ST Guide Wire (K-wire)	WS-0906ST
<b>Extension Plates</b>		44		Frag-Loc 2.5 mm Drill	80-0724
21	Acu-Loc 2 VDR Extension Plate Long, Left	70-0365	45	Frag-Loc Depth Gauge	80-0726
22	Acu-Loc 2 VDR Extension Plate Long, Right	70-0366	46	Acu-Loc 2 Implant Platter	80-0752
23	Acu-Loc 2 VDR Extension Plate, Neutral	70-0364	<b>Optional Instrument</b>		
24	Acu-Loc 2 VDR Hexalobe Extension Link Screw	30-0100	Acu-Loc 2 VDR Targeting Guide Locking Bolt, Long		80-1071
				Locking Bolt 10-32	80-0738



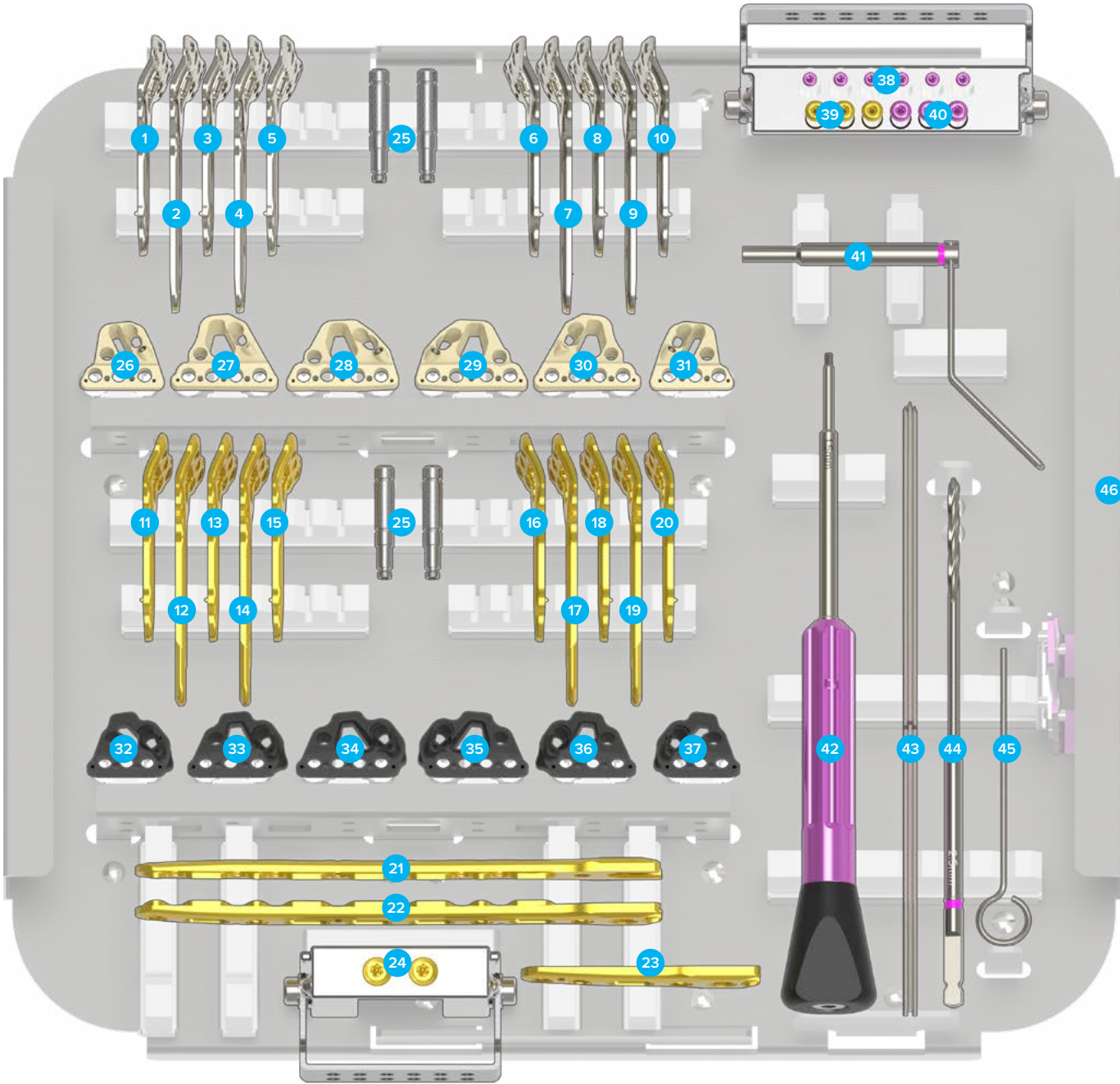

## Ordering Information [continued]

Tray Components			
<b>Acu-Loc Plates</b>		<b>Instrumentation</b>	
1	Acu-Loc Dorsal Plate, Narrow, Left	70-0057	17 Locking Screw, Acu-Loc Radiolucent Targeting Guide
2	Acu-Loc Dorsal Plate, Standard, Left	70-0055	18 Acu-Loc Dorsal Plate Targeting Guide Narrow, Left
3	Acu-Loc Dorsal Plate, Standard, Right	70-0056	19 Acu-Loc Dorsal Plate Targeting Guide Standard, Left
4	Acu-Loc Dorsal Plate, Narrow, Right	70-0058	20 Acu-Loc Dorsal Targeting Guide Standard, Right
5	Acu-Loc VDU Plate, Standard, Left	70-0045	21 Acu-Loc Dorsal Targeting Guide Narrow, Right
6	Acu-Loc VDU Plate, Long, Left	70-0047	22 Acu-Loc EX Targeting Guide Standard
7	Acu-Loc VDU Plate, Long, Right	70-0048	23 Acu-Loc EX Targeting Guide Narrow
8	Acu-Loc VDU Plate, Standard, Right	70-0046	24 2.0 mm Locking Drill Guide 6–46 mm
9	Acu-Loc EX Standard	70-0063	25 2.3 mm Bone Tap
10	Acu-Loc EX Narrow	70-0064	26 Small Plate Bender
<b>Distal Radius Fragment Specific (DRFS) Plates</b>		<b>Variable Angle Instrumentation</b>	
11	Dorsal Rim Buttress Plate, Right	70-0335	27 1.7 mm Quick Coupler Semi-fluted Drill
12	Dorsal Rim Buttress Plate, Left	70-0336	28 Mini-AO Torque Limiting Driver, 10 in-lb
13	Divergent Radial Styloid Plate	70-0331	29 2.3 mm Screw Depth Gauge 6–46 mm
14	Volar Lunate Suture Plate	70-0334	30 2.3 mm Variable Angle Drill Guide Driver
15	Dorsal Lunate Plate, Right	70-0337	31 2.3 mm Variable Angle Drill Guide
16	Dorsal Lunate Plate, Left	70-0338	
Trays & Inserts			
32	Hand & Wrist Implant Platter	80-0787	<b>Variable Angle Screw Inserts</b>
<b>Distal Radius Fragment Specific Inserts</b>			36 2.3 mm Variable Angle Screw Insert
33	Distal Radius Fragment Specific Insert	80-0822	37 2.3 mm Variable Screw Caddy Lid
34	2.3 mm Long Screw Caddy Base	80-0825	38 2.3 mm Variable Screw Caddy Base
35	2.3 mm Long Screw Caddy Lid	80-0762	

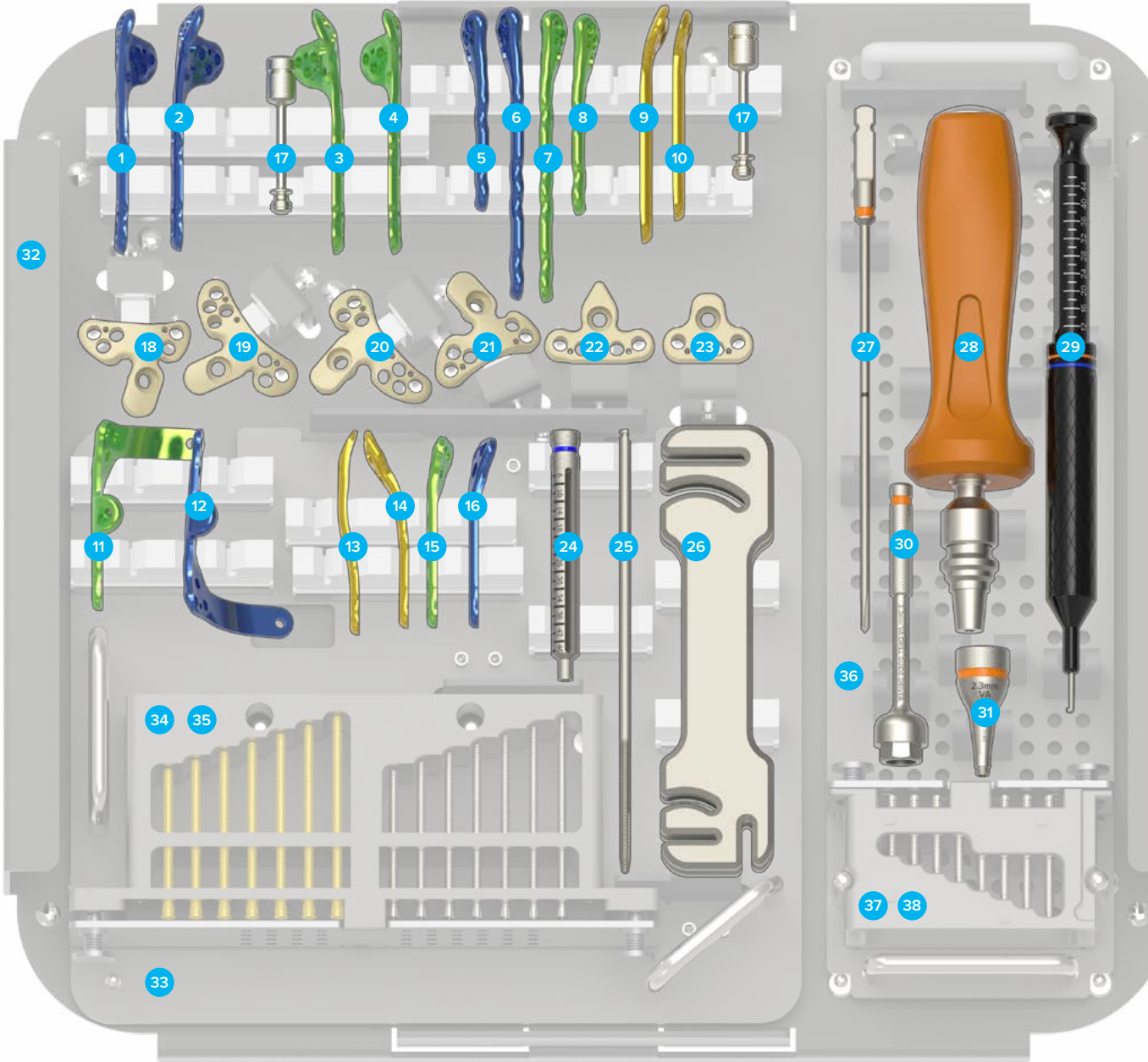

## Ordering Information [continued]

Tray Components					
<b>3.5 mm Instrumentation</b>		<b>2.3 mm Instrumentation</b>			
1	2.8 mm Quick Release Drill	80-0387	4	2.3 mm Screw Sleeve, Locking Tab	80-0727
2	2.8 mm Hexalobe Locking Drill Guide 6–65 mm	80-0668	5	1.5 mm Hex Driver Tip, Locking Groove	80-0728
3	T15 Stick Fit Hexalobe Driver	80-0760	6	2.0 mm Locking Drill Guide 4–32 mm	80-0249
			7	.054" K-wire Guide	80-0688
			8	Drill Guide / Depth Gauge for 2.0 mm Drill	MS-DG23
			9	Distal Radius Probe	MS-DRPB
			10	2.0 mm Quick Release Drill	80-0318
Trays & Inserts					
11	Universal Tray Screw Insert Base	80-0346	<b>2.3 mm</b>		
<b>3.5 mm</b>			14	2.3 mm Screw Caddy	80-0748
12	3.5 mm Hexalobe Hand & Wrist Caddy	80-1500	15	2.3 mm / 3.5 mm Screw Caddy Lid	80-0790*
13	3.5 mm Hexalobe Hand & Wrist Caddy Lid	80-1502*			
Optional					
<b>3.5 mm Screw Instrumentation</b>					
	2.8 mm x 5" Quick Release Drill	80-2008			
	2.8 mm Locking Drill Guide 6–26 mm	80-2006			
	3.5 mm Locking Screw Bone Tap	80-2126			

\*Items not shown

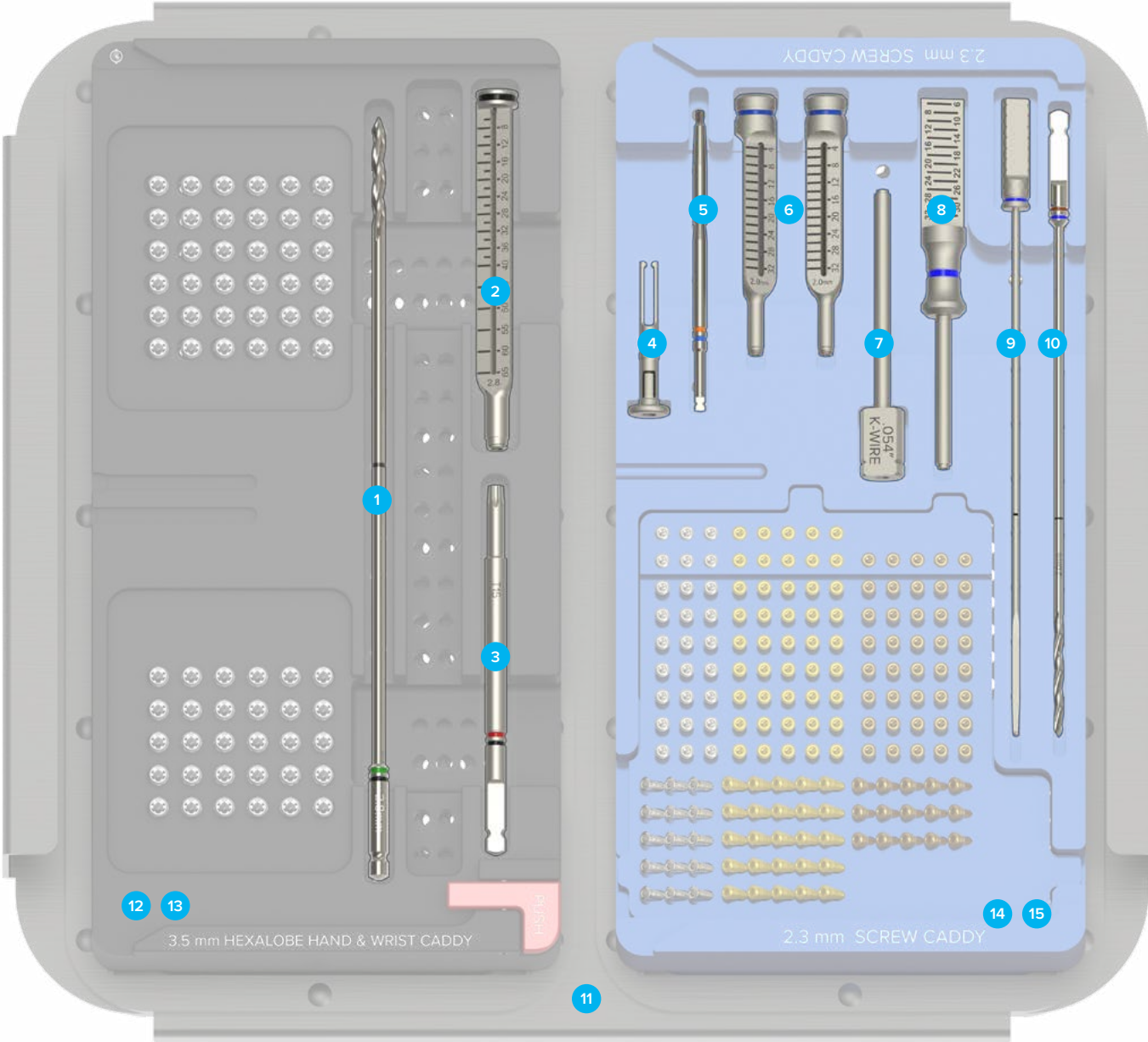



## Ordering Information [continued]

2.3 mm Screws			
2.3 mm Nontoggling Cortical Screws	2.3 mm Locking Variable Angle Screws		
2.3 mm x 8 mm Nontoggling Cortical Screw	CO-N2308	2.3 mm x 14 mm Locking Variable Angle Screw	30-2314
2.3 mm x 10 mm Nontoggling Cortical Screw	CO-N2310	2.3 mm x 16 mm Locking Variable Angle Screw	30-2316
2.3 mm x 12 mm Nontoggling Cortical Screw	CO-N2312	2.3 mm x 18 mm Locking Variable Angle Screw	30-2318
2.3 mm x 14 mm Nontoggling Cortical Screw	CO-N2314	2.3 mm x 20 mm Locking Variable Angle Screw	30-2320
2.3 mm x 16 mm Nontoggling Cortical Screw	CO-N2316	2.3 mm x 22 mm Locking Variable Angle Screw	30-2322
2.3 mm x 18 mm Nontoggling Cortical Screw	CO-N2318	2.3 mm x 24 mm Locking Variable Angle Screw	30-2324
2.3 mm x 20 mm Nontoggling Cortical Screw	CO-N2320	2.3 mm x 26 mm Locking Variable Angle Screw	30-2326
2.3 mm x 22 mm Nontoggling Cortical Screw	CO-N2322	2.3 mm x 28 mm Locking Variable Angle Screw	30-2328
2.3 mm x 24 mm Nontoggling Cortical Screw	CO-N2324		
2.3 mm x 26 mm Nontoggling Cortical Screw	CO-N2326		
2.3 mm x 28 mm Nontoggling Cortical Screw	CO-N2328		
2.3 mm x 30 mm Nontoggling Cortical Screw	CO-N2330		
2.3 mm x 32 mm Nontoggling Cortical Screw	CO-N2332		
2.3 mm x 34 mm Nontoggling Cortical Screw	CO-N2334		
2.3 mm x 36 mm Nontoggling Cortical Screw	CO-N2336		
2.3 mm x 38 mm Nontoggling Cortical Screw	CO-N2338		
2.3 mm x 40 mm Nontoggling Cortical Screw	CO-N2340		
2.3 mm x 42 mm Nontoggling Cortical Screw	CO-N2342		
2.3 mm x 44 mm Nontoggling Cortical Screw	CO-N2344		
2.3 mm x 46 mm Nontoggling Cortical Screw	CO-N2346		



## Ordering Information [continued]

2.3 mm Screws			
2.3 mm Locking Cortical Pegs		2.3 mm Locking Cortical Screws	
2.3 mm x 8 mm Locking Cortical Peg	CO-S2308	2.3 mm x 8 mm Locking Cortical Screw	CO-T2308
2.3 mm x 10 mm Locking Cortical Peg	CO-S2310	2.3 mm x 10 mm Locking Cortical Screw	CO-T2310
2.3 mm x 12 mm Locking Cortical Peg	CO-S2312	2.3 mm x 12 mm Locking Cortical Screw	CO-T2312
2.3 mm x 14 mm Locking Cortical Peg	CO-S2314	2.3 mm x 14 mm Locking Cortical Screw	CO-T2314
2.3 mm x 16 mm Locking Cortical Peg	CO-S2316	2.3 mm x 16 mm Locking Cortical Screw	CO-T2316
2.3 mm x 18 mm Locking Cortical Peg	CO-S2318	2.3 mm x 18 mm Locking Cortical Screw	CO-T2318
2.3 mm x 20 mm Locking Cortical Peg	CO-S2320	2.3 mm x 20 mm Locking Cortical Screw	CO-T2320
2.3 mm x 22 mm Locking Cortical Peg	CO-S2322	2.3 mm x 22 mm Locking Cortical Screw	CO-T2322
2.3 mm x 24 mm Locking Cortical Peg	CO-S2324	2.3 mm x 24 mm Locking Cortical Screw	CO-T2324
2.3 mm x 26 mm Locking Cortical Peg	CO-S2326	2.3 mm x 26 mm Locking Cortical Screw	CO-T2326
2.3 mm x 28 mm Locking Cortical Peg	CO-S2328	2.3 mm x 28 mm Locking Cortical Screw	CO-T2328
		2.3 mm x 30 mm Locking Cortical Screw	CO-T2330
		2.3 mm x 32 mm Locking Cortical Screw	CO-T2332
		2.3 mm x 34 mm Locking Cortical Screw	CO-T2334
		2.3 mm x 36 mm Locking Cortical Screw	CO-T2336
		2.3 mm x 38 mm Locking Cortical Screw	CO-T2338
		2.3 mm x 40 mm Locking Cortical Screw	CO-T2340
		2.3 mm x 42 mm Locking Cortical Screw	CO-T2342
		2.3 mm x 44 mm Locking Cortical Screw	CO-T2344
		2.3 mm x 46 mm Locking Cortical Screw	CO-T2346

## Ordering Information [continued]

Optional 2.7 mm Low-Profile Screws			
2.7 mm Low-Profile Hexalobe Nonlocking Screws		2.7 mm Low-Profile Hexalobe Locking Screws	
2.7 x 9 mm Low-Profile Hexalobe – Nonlocking	3041-23009	2.7 x 8 mm Low-Profile Hexalobe – Locking	3040-23008
2.7 x 10 mm Low-Profile Hexalobe – Nonlocking	3041-23010	2.7 x 9 mm Low-Profile Hexalobe – Locking	3040-23009
2.7 x 11 mm Low-Profile Hexalobe – Nonlocking	3041-23011	2.7 x 10 mm Low-Profile Hexalobe – Locking	3040-23010
2.7 x 12 mm Low-Profile Hexalobe – Nonlocking	3041-23012	2.7 x 11 mm Low-Profile Hexalobe – Locking	3040-23011
2.7 x 13 mm Low-Profile Hexalobe – Nonlocking	3041-23013	2.7 x 12 mm Low-Profile Hexalobe – Locking	3040-23012
2.7 x 14 mm Low-Profile Hexalobe – Nonlocking	3041-23014	2.7 x 13 mm Low-Profile Hexalobe – Locking	3040-23013
2.7 x 15 mm Low-Profile Hexalobe – Nonlocking	3041-23015	2.7 x 14 mm Low-Profile Hexalobe – Locking	3040-23014
2.7 x 16 mm Low-Profile Hexalobe – Nonlocking	3041-23016	2.7 x 15 mm Low-Profile Hexalobe – Locking	3040-23015
2.7 x 17 mm Low-Profile Hexalobe – Nonlocking	3041-23017	2.7 x 16 mm Low-Profile Hexalobe – Locking	3040-23016
2.7 x 18 mm Low-Profile Hexalobe – Nonlocking	3041-23018	2.7 x 17 mm Low-Profile Hexalobe – Locking	3040-23017
2.7 x 19 mm Low-Profile Hexalobe – Nonlocking	3041-23019	2.7 x 18 mm Low-Profile Hexalobe – Locking	3040-23018
		2.7 x 19 mm Low-Profile Hexalobe – Locking	3040-23019

## Ordering Information [continued]

### Optional Sterile 2.7 mm Low-Profile Screws

#### 2.7 mm Low-Profile Hexalobe Nonlocking

2.7 x 9 mm Low-Profile Hexalobe – Nonlocking	3041-23009-S
2.7 x 10 mm Low-Profile Hexalobe – Nonlocking	3041-23010-S
2.7 x 11 mm Low-Profile Hexalobe – Nonlocking	3041-23011-S
2.7 x 12 mm Low-Profile Hexalobe – Nonlocking	3041-23012-S
2.7 x 13 mm Low-Profile Hexalobe – Nonlocking	3041-23013-S
2.7 x 14 mm Low-Profile Hexalobe – Nonlocking	3041-23014-S
2.7 x 15 mm Low-Profile Hexalobe – Nonlocking	3041-23015-S
2.7 x 16 mm Low-Profile Hexalobe – Nonlocking	3041-23016-S
2.7 x 17 mm Low-Profile Hexalobe – Nonlocking	3041-23017-S
2.7 x 18 mm Low-Profile Hexalobe – Nonlocking	3041-23018-S
2.7 x 19 mm Low-Profile Hexalobe – Nonlocking	3041-23019-S

#### 2.7 mm Low-Profile Hexalobe Locking

2.7 x 8 mm Low-Profile Hexalobe – Locking	3040-23008-S
2.7 x 9 mm Low-Profile Hexalobe – Locking	3040-23009-S
2.7 x 10 mm Low-Profile Hexalobe – Locking	3040-23010-S
2.7 x 11 mm Low-Profile Hexalobe – Locking	3040-23011-S
2.7 x 12 mm Low-Profile Hexalobe – Locking	3040-23012-S
2.7 x 13 mm Low-Profile Hexalobe – Locking	3040-23013-S
2.7 x 14 mm Low-Profile Hexalobe – Locking	3040-23014-S
2.7 x 15 mm Low-Profile Hexalobe – Locking	3040-23015-S
2.7 x 16 mm Low-Profile Hexalobe – Locking	3040-23016-S
2.7 x 17 mm Low-Profile Hexalobe – Locking	3040-23017-S
2.7 x 18 mm Low-Profile Hexalobe – Locking	3040-23018-S
2.7 x 19 mm Low-Profile Hexalobe – Locking	3040-23019-S

## Ordering Information [continued]

### Tray Components

#### 2.7 mm Low-Profile Screw Instrumentation

1	Depth Gauge 6–65 mm	80-0623*	5	Universal Tray Utility Insert	80-0347
2	2.0 mm Quick Release Drill	80-0318*	6	Acu-Loc 2 2.7 mm Low-Profile Screw Caddy	80-3926
3	T8 Stick Fit Hexalobe Driver	80-0759	7	2.7 mm Low-Profile Screw Caddy Lid	80-3927**
4	2.0 mm Hexalobe Locking Drill Guide 6–26 mm	80-4029			

\* Depth Gauge 6–65 mm 80-0623 and 2.0 mm Quick Release Drill 80-0318 already comes standard with the 2.3 mm screws

\*\*Items not shown

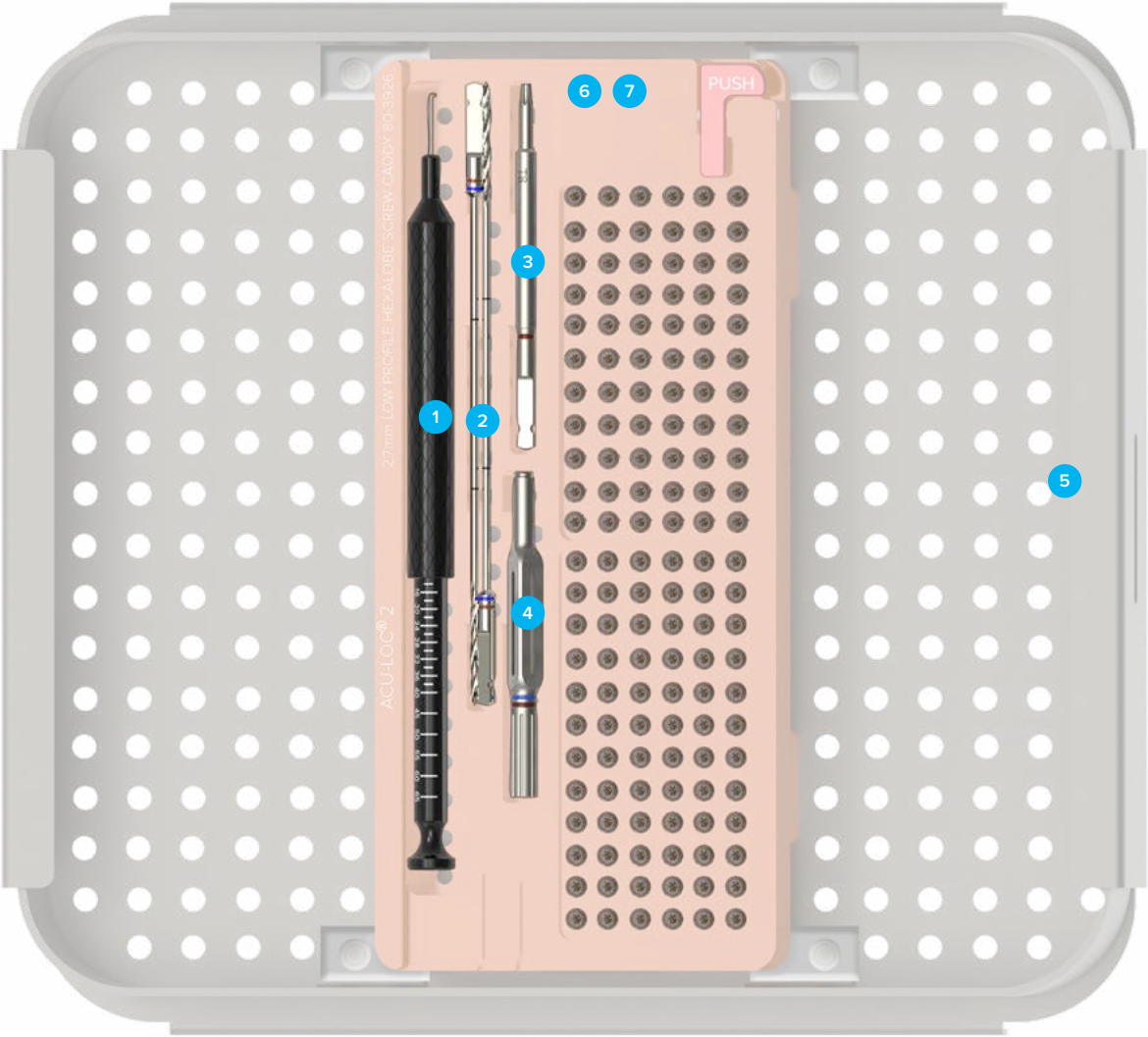

## Ordering Information [continued]

Sterile Tray Components			
<b>Acu-Loc 2 Volar Distal Radius (VDR) Plates</b>		<b>Frag-Loc® Screws</b>	
Acu-Loc 2 VDR Plate Narrow, Left	70-0358-S	Frag-Loc Compression Sleeve	30-0370-S
Acu-Loc 2 VDR Plate Narrow Long, Left	70-0370-S	Frag-Loc Compression Screw, Long	30-0372-S
Acu-Loc 2 VDR Plate Standard, Left	70-0356-S	Frag-Loc Compression Screw	30-0371-S
Acu-Loc 2 VDR Plate Standard Long, Left	70-0368-S	<b>Frag-Loc® Instrumentation</b>	
Acu-Loc 2 VDR Plate Wide, Left	70-0360-S	Frag-Loc 2.5 mm Drill	80-0724-S
Acu-Loc 2 VDR Plate Wide, Right	70-0361-S	<b>Acu-Loc Plates</b>	
Acu-Loc 2 VDR Plate Standard Long, Right	70-0369-S	Acu-Loc Dorsal Plate, Narrow, Left	70-0057-S
Acu-Loc 2 VDR Plate Standard, Right	70-0357-S	Acu-Loc Dorsal Plate, Standard, Left	70-0055-S
Acu-Loc 2 VDR Plate Narrow Long, Right	70-0371-S	Acu-Loc Dorsal Plate, Standard, Right	70-0056-S
Acu-Loc 2 VDR Plate Narrow, Right	70-0359-S	Acu-Loc Dorsal Plate, Narrow, Right	70-0058-S
<b>Acu-Loc 2 Volar Distal Radius (VDR) Proximal Plates</b>		Acu-Loc VDU Plate, Standard, Left	70-0045-S
Acu-Loc 2 VDR Proximal Plate Narrow, Left	70-0352-S	Acu-Loc VDU Plate, Long, Left	70-0047-S
Acu-Loc 2 VDR Proximal Plate Narrow Long, Left	70-0382-S	Acu-Loc VDU Plate, Long, Right	70-0048-S
Acu-Loc 2 VDR Proximal Plate Standard, Left	70-0350-S	Acu-Loc VDU Plate, Standard, Right	70-0046-S
Acu-Loc 2 VDR Proximal Plate Standard Long, Left	70-0372-S	Acu-Loc EX Standard	70-0063-S
Acu-Loc 2 VDR Proximal Plate Wide, Left	70-0354-S	Acu-Loc EX Narrow	70-0064-S
Acu-Loc 2 VDR Proximal Plate Wide, Right	70-0355-S	<b>Distal Radius Fragment Specific (DRFS) Plates</b>	
Acu-Loc 2 VDR Proximal Plate Standard Long, Right	70-0373-S	Dorsal Rim Buttress Plate, Right	70-0335-S
Acu-Loc 2 VDR Proximal Plate Standard, Right	70-0351-S	Dorsal Rim Buttress Plate, Left	70-0336-S
Acu-Loc 2 VDR Proximal Plate Narrow Long, Right	70-0383-S	Divergent Radial Styloid Plate	70-0331-S
Acu-Loc 2 VDR Proximal Plate Narrow, Right	70-0353-S	Volar Lunate Suture Plate	70-0334-S
<b>Extension Plates</b>		Dorsal Lunate Plate, Right	70-0337-S
Acu-Loc 2 VDR Extension Plate Long, Left	70-0365-S	Dorsal Lunate Plate, Left	70-0338-S
Acu-Loc 2 VDR Extension Plate Long, Right	70-0366-S		
Acu-Loc 2 VDR Extension Plate, Neutral	70-0364-S		
Acu-Loc 2 VDR Hexalobe Extension Link Screw	30-0100-S		



## Ordering Information [continued]

Sterile Tray Components			
<b>Instrumentation</b>		<b>3.5 mm Instrumentation</b>	
1.5 mm Easyout, Quick Release	80-0598-S	2.8 mm Quick Release Drill	80-0387-S
2.5 mm Easyout, Quick Release	80-0600-S	<b>2.3 mm Instrumentation</b>	
Plate Tack	PL-PTACK-S	2.0 mm Quick Release Drill	80-0318-S
Sterile 2.3 mm Screws			
<b>2.3 mm Locking Cortical Pegs</b>		<b>2.3 mm Locking Cortical Screws</b>	
2.3 mm x 8 mm Locking Cortical Peg	CO-S2308-S	2.3 mm x 8 mm Locking Cortical Screw	CO-T2308-S
2.3 mm x 10 mm Locking Cortical Peg	CO-S2310-S	2.3 mm x 10 mm Locking Cortical Screw	CO-T2310-S
2.3 mm x 12 mm Locking Cortical Peg	CO-S2312-S	2.3 mm x 12 mm Locking Cortical Screw	CO-T2312-S
2.3 mm x 14 mm Locking Cortical Peg	CO-S2314-S	2.3 mm x 14 mm Locking Cortical Screw	CO-T2314-S
2.3 mm x 16 mm Locking Cortical Peg	CO-S2316-S	2.3 mm x 16 mm Locking Cortical Screw	CO-T2316-S
2.3 mm x 18 mm Locking Cortical Peg	CO-S2318-S	2.3 mm x 18 mm Locking Cortical Screw	CO-T2318-S
2.3 mm x 20 mm Locking Cortical Peg	CO-S2320-S	2.3 mm x 20 mm Locking Cortical Screw	CO-T2320-S
2.3 mm x 22 mm Locking Cortical Peg	CO-S2322-S	2.3 mm x 22 mm Locking Cortical Screw	CO-T2322-S
2.3 mm x 24 mm Locking Cortical Peg	CO-S2324-S	2.3 mm x 24 mm Locking Cortical Screw	CO-T2324-S
2.3 mm x 26 mm Locking Cortical Peg	CO-S2326-S	2.3 mm x 26 mm Locking Cortical Screw	CO-T2326-S
2.3 mm x 28 mm Locking Cortical Peg	CO-S2328-S	2.3 mm x 28 mm Locking Cortical Screw	CO-T2328-S
		2.3 mm x 30 mm Locking Cortical Screw	CO-T2330-S
		2.3 mm x 32 mm Locking Cortical Screw	CO-T2332-S
		2.3 mm x 34 mm Locking Cortical Screw	CO-T2334-S
		2.3 mm x 36 mm Locking Cortical Screw	CO-T2336-S
		2.3 mm x 38 mm Locking Cortical Screw	CO-T2338-S
		2.3 mm x 40 mm Locking Cortical Screw	CO-T2340-S
		2.3 mm x 42 mm Locking Cortical Screw	CO-T2342-S
		2.3 mm x 44 mm Locking Cortical Screw	CO-T2344-S
		2.3 mm x 46 mm Locking Cortical Screw	CO-T2346-S

## Ordering Information [continued]

3.5 mm Screws			
3.5 mm Locking Hexalobe Screws		3.5 mm Nonlocking Hexalobe Screws	
3.5 mm x 8 mm Locking Hexalobe Screw	30-0232	3.5 mm x 10 mm Nonlocking Hexalobe Screw	30-0256
3.5 mm x 10 mm Locking Hexalobe Screw	30-0233	3.5 mm x 12 mm Nonlocking Hexalobe Screw	30-0257
3.5 mm x 12 mm Locking Hexalobe Screw	30-0234	3.5 mm x 14 mm Nonlocking Hexalobe Screw	30-0258
3.5 mm x 14 mm Locking Hexalobe Screw	30-0235	3.5 mm x 16 mm Nonlocking Hexalobe Screw	30-0259
3.5 mm x 16 mm Locking Hexalobe Screw	30-0236	3.5 mm x 18 mm Nonlocking Hexalobe Screw	30-0260
3.5 mm x 18 mm Locking Hexalobe Screw	30-0237		

Sterile 3.5 mm Screws			
3.5 mm Locking Hexalobe Screws		3.5 mm Nonlocking Hexalobe Screws	
3.5 mm x 8 mm Locking Hexalobe Screw	30-0232-S	3.5 mm x 9 mm Nonlocking Hexalobe Screw	30-0224-S
3.5 mm x 9 mm Locking Hexalobe Screw	30-0218-S	3.5 mm x 10 mm Nonlocking Hexalobe Screw	30-0256-S
3.5 mm x 10 mm Locking Hexalobe Screw	30-0233-S	3.5 mm x 11 mm Nonlocking Hexalobe Screw	30-0225-S
3.5 mm x 11 mm Locking Hexalobe Screw	30-0219-S	3.5 mm x 12 mm Nonlocking Hexalobe Screw	30-0257-S
3.5 mm x 12 mm Locking Hexalobe Screw	30-0234-S	3.5 mm x 13 mm Nonlocking Hexalobe Screw	30-0226-S
3.5 mm x 13 mm Locking Hexalobe Screw	30-0220-S	3.5 mm x 14 mm Nonlocking Hexalobe Screw	30-0258-S
3.5 mm x 14 mm Locking Hexalobe Screw	30-0235-S	3.5 mm x 15 mm Nonlocking Hexalobe Screw	30-0227-S
3.5 mm x 15 mm Locking Hexalobe Screw	30-0221-S	3.5 mm x 16 mm Nonlocking Hexalobe Screw	30-0259-S
3.5 mm x 16 mm Locking Hexalobe Screw	30-0236-S	3.5 mm x 17 mm Nonlocking Hexalobe Screw	30-0228-S
3.5 mm x 17 mm Locking Hexalobe Screw	30-0222-S	3.5 mm x 18 mm Nonlocking Hexalobe Screw	30-0260-S
3.5 mm x 18 mm Locking Hexalobe Screw	30-0237-S	3.5 mm x 19 mm Nonlocking Hexalobe Screw	30-0229-S
3.5 mm x 19 mm Locking Hexalobe Screw	30-0223-S		

## Ordering Information [continued]

Optional			
<b>3.5 mm Locking Cortical Screws</b>		<b>3.5 mm Cortical Screws</b>	
3.5 mm x 8 mm Locking Cortical Screw	COL-3080	3.5 mm x 10 mm Cortical Screw	CO-3100
3.5 mm x 10 mm Locking Cortical Screw	COL-3100	3.5 mm x 12 mm Cortical Screw	CO-3120
3.5 mm x 12 mm Locking Cortical Screw	COL-3120	3.5 mm x 14 mm Cortical Screw	CO-3140
3.5 mm x 14 mm Locking Cortical Screw	COL-3140	3.5 mm x 16 mm Cortical Screw	CO-3160
3.5 mm x 16 mm Locking Cortical Screw	COL-3160	3.5 mm x 18 mm Cortical Screw	CO-3180
3.5 mm x 18 mm Locking Cortical Screw	COL-3180	<b>Acu-Loc 2 VDR Extension Plate Screws</b>	
<b>Instrumentation</b>		Acu-Loc 2 VDR Plate Extension Link Screw	30-0093
2.5 mm Quick Release Hex Driver	HPC-0025		
3.5 mm Screw Driver Sleeve	MS-SS35		
2.8 mm Locking Drill Guide 6–65 mm	80-0384		

Optional Sterile Screws			
<b>3.5 mm Locking Cortical Screws</b>		<b>3.5 mm Cortical Screws</b>	
3.5 mm x 8 mm Locking Cortical Screw	COL-3080-S	3.5 mm x 10 mm Cortical Screw	CO-3100-S
3.5 mm x 10 mm Locking Cortical Screw	COL-3100-S	3.5 mm x 12 mm Cortical Screw	CO-3120-S
3.5 mm x 12 mm Locking Cortical Screw	COL-3120-S	3.5 mm x 14 mm Cortical Screw	CO-3140-S
3.5 mm x 14 mm Locking Cortical Screw	COL-3140-S	3.5 mm x 16 mm Cortical Screw	CO-3160-S
3.5 mm x 16 mm Locking Cortical Screw	COL-3160-S	3.5 mm x 18 mm Cortical Screw	CO-3180-S
3.5 mm x 18 mm Locking Cortical Screw	COL-3180-S	<b>Acu-Loc 2 VDR Extension Plate Screws</b>	
		Acu-Loc 2 VDR Plate Extension Link Screw	30-0093-S

Additional Components			
<b>Instruments</b>			
Acu-Loc Dorsal Add-On X-Ray Template	90-0007	Acu-Loc 2 Frag-Loc® X-Ray Template	90-0033
Acu-Loc VDU Add-On X-Ray Template	90-0014	<b>Trays</b>	
Acu-Loc EX Add-On X-Ray Template	90-0015	Acu-Loc 2 System Case Lid	80-0673
Acu-Loc 2 VDR Plate X-Ray Template	90-0030	Acu-Loc 2 System Case Base	80-0674
Acu-Loc 2 VDR Proximal Plate X-Ray Template	90-0031	2.3 mm Long Screw Caddy Lid	80-0826
Acu-Loc 2 Extension Plate X-Ray Template	90-0032		

## Ordering Information [continued]

Trial Plates			
<b>Trial Acu-Loc 2 Volar Distal Radius (VDR) Plates</b>		<b>Trial Acu-Loc Plates</b>	
Trial Acu-Loc 2 VDR Plate Standard, Left	71-0356	Trial Acu-Loc Dorsal Plate Standard, Left	75-0055
Trial Acu-Loc 2 VDR Plate Standard, Right	71-0357	Trial Acu-Loc Dorsal Plate Standard, Right	75-0056
Trial Acu-Loc 2 VDR Plate Narrow, Left	71-0358	Trial Acu-Loc Dorsal Plate Narrow, Left	75-0057
Trial Acu-Loc 2 VDR Plate Narrow, Right	71-0359	Trial Acu-Loc Dorsal Plate Narrow, Right	75-0058
Trial Acu-Loc 2 VDR Plate Wide, Left	71-0360	Trial Acu-Loc EX Standard	75-0063
Trial Acu-Loc 2 VDR Plate Wide, Right	71-0361	Trial Acu-Loc EX Narrow	75-0064
Trial Acu-Loc 2 VDR Plate Standard Long, Left	71-0368	Trial Acu-Loc VDU Plate Standard, Left	75-0045
Trial Acu-Loc 2 VDR Plate Standard Long, Right	71-0369	Trial Acu-Loc VDU Plate Standard, Right	75-0046
Trial Acu-Loc 2 VDR Plate Narrow Long, Left	71-0370	Trial Acu-Loc VDU Plate Long, Left	75-0047
Trial Acu-Loc 2 VDR Plate Narrow Long, Right	71-0371	Trial Acu-Loc VDU Plate Long, Right	75-0048
<b>Trial Acu-Loc 2 Volar Distal Radius (VDR) Proximal Plates</b>		<b>Trial Distal Radius Fragment Specific (DRFS) Plates</b>	
Trial Acu-Loc 2 VDR Proximal Plate Standard Long, Left	71-0372	Trial Divergent Radial Styloid Plate	71-0331
Trial Acu-Loc 2 VDR Proximal Plate Standard Long, Right	71-0373	Trial Volar Lunate Suture Plate	71-0334
Trial Acu-Loc 2 VDR Proximal Plate Narrow Long, Left	71-0382	Trial Dorsal Rim Buttress Plate, Right	71-0335
Trial Acu-Loc 2 VDR Proximal Plate Narrow Long, Right	71-0383	Trial Dorsal Rim Buttress Plate, Left	71-0336
Trial Acu-Loc 2 VDR Proximal Plate Standard, Left	71-0350	Trial Dorsal Lunate Plate, Right	71-0337
Trial Acu-Loc 2 VDR Proximal Plate Standard, Right	71-0351	Trial Dorsal Lunate Plate, Left	71-0338
Trial Acu-Loc 2 VDR Proximal Plate Narrow, Left	71-0352	<b>Trial Extension Plates</b>	
Trial Acu-Loc 2 VDR Proximal Plate Narrow, Right	71-0353	Trial Acu-Loc 2 VDR Extension Plate, Neutral	71-0364
Trial Acu-Loc 2 VDR Proximal Plate Wide, Left	71-0354	Trial Acu-Loc 2 VDR Extension Plate Long, Left	71-0365
Trial Acu-Loc 2 VDR Proximal Plate Wide, Right	71-0355	Trial Acu-Loc 2 VDR Extension Plate Long, Right	71-0366

## References

1. Geissler WB, Clark SM. Fragment-specific fixation for fractures of the distal radius. *J Wrist Surg.* 2016;5(1):22–30.
2. Shapiro L, Kamal, R. Distal radius fragment-specific fixation. *J Orthop Trauma.* 2019.



Acumed Headquarters  
5885 NE Cornelius Pass Road  
Hillsboro, OR 97124  
Office: +1.888.627.9957  
Office: +1.503.627.9957  
Fax: +1.503.520.9618  
[www.acumed.net](http://www.acumed.net)

These materials contain information about products that may or may not be available in any particular country or may be available under different trademarks in different countries. The products may be approved or cleared by governmental regulatory organizations for sale or use with different indications or restrictions in different countries. Products may not be approved for use in all countries. Nothing contained in these materials should be construed as a promotion or solicitation for any product or for the use of any product in a particular way that is not authorized under the laws and regulations of the country where the reader is located. Nothing in these materials should be construed as a representation or warranty as to the efficacy or quality of any product, nor the appropriateness of any product to treat any specific condition. Physicians may direct questions about the availability and use of the products described in these materials to their authorized Acumed distributor. Specific questions patients may have about the use of the products described in these materials or the appropriateness for their own conditions should be directed to their own physician.

**HNW00-06-AB** | Effective: 2020/11 | © 2020 Acumed® LLC